

United States
Department of
Agriculture

Forest Service

Forest
Products
Laboratory

General
Technical
Report
FPL-GTR-69

In cooperation
with the
Southern Pine
Marketing Council



Exterior Wood in the South

Selection, Applications, and Finishes

Daniel L. Cassens
William C. Feist



Abstract

Wood continues to play an important role as a structural material in today's high-tech society. As lumber and in reconstituted products, wood is commonly used for house siding, trim, decks, fences, and countless other exterior and interior applications. When wood is exposed to the elements, particularly sunlight and moisture, special precautions must be taken in structural design as well as in the selection and application of the finish. This is especially true in the South, where excessive moisture can quickly damage a structure and erode the finish.

This report describes the characteristics of wood finishes and their proper application to solid and reconstituted wood products. It describes how manufacturing and construction practices affect the surfaces of wood products, how various types of finishes interact with the surface, and how weathering affects the finished surfaces. Methods for selecting and applying various exterior wood finishes are presented. Finally, the failure and discoloration of wood finishes are discussed, and methods are described for preventing these problems. The information and advice given in this report provide a guide for obtaining maximum service life for finished exterior wood products in the South.

May 1991

Cassens, Daniel L.; Feist, William C. 1991. Exterior Wood in the South: Selection, Applications, and Finishes. Gen. Tech. Rep. FPL-GTR-69. Madison, WI: U.S. Department of Agriculture, Forest Service, Forest Products Laboratory. 60p.

A limited number of free copies of this publication are available to the public from the Forest Products Laboratory, One Gifford Pinchot Drive, Madison, WI 53705-2398. Laboratory publications are sent to more than 1,000 libraries in the United States and elsewhere.

The Forest Products Laboratory is maintained in cooperation with the University of Wisconsin.

This publication is also available from



**Southern Pine
Marketing Council**

Southern Forest Products Association
P.O. Box 52468 New Orleans, LA 70152 (504) 443-4464

Southeastern Lumber Manufacturers Association
P.O. Box 1788 Forest Park, GA 30051 (404) 361-1445

Exterior Wood in the South

Selection, Applications, and Finishes

Daniel L. Cassens

Professor of Wood Products
Department of Forestry and Natural Resources
Purdue University
West Lafayette, Indiana

and

William C. Feist

Project Leader
Wood Surface Chemistry and Protection
USDA Forest Service
Forest Products Laboratory
Madison, Wisconsin

Acknowledgment

This report was developed with assistance from the Technology Transfer Team on Finishing Wood Exteriors in the South.

Terry Amburgey
Professor
Mississippi State University
Forest Products Utilization Laboratory
Mississippi State, Mississippi

Julian Beckwith III
Wood Products Specialist
University of Georgia
Extension Service
Athens, Georgia

Brian Buchanan
Wood Technologist
Texas Forest Service
Forest Products Laboratory
Lufkin, Texas

A.B. Curtis, Jr.
Forest Products Technologist
USDA Forest Service
Jackson, Mississippi

Bob Daniels
Wood Utilization Forester
Mississippi State Extension
Forestry Department
Mississippi State, Mississippi

Jeff K. Easterling
Treated Markets Manager
Southern Forest Products Association
New Orleans, Louisiana

Jim Geisler
Extension Forester
University of Arkansas
Extension Service
Little Rock, Arkansas

Larry Jahn
Extension Forest Resources Specialist
North Carolina State University
Extension Service
Raleigh, North Carolina

Ed Langwig
Professor Emeritus of Forestry
Oklahoma State University
Stillwater, Oklahoma

Joseph Loferski
Assistant Professor of Wood Engineering
Virginia Tech University
Extension Service
Blacksburg, Virginia

Maxine McManus
Associate Professor and Leader
Housing and Equipment
University of Tennessee
Extension Service
Knoxville, Tennessee

Robert Mills
Forestry Specialist
Louisiana State University
Extension Service
Baton Rouge, Louisiana

Jim Neal
Regional Extension Forester
University of Georgia Extension Service
Athens, Georgia

Ted Peterson
Program Leader
National Wood Products Extension Program
University of Wisconsin Extension Service
Madison, Wisconsin

Don Stumbo
Professor of Wood Products
University of Tennessee
Department of Forestry
Knoxville, Tennessee

Partial funding for development and printing of this publication has been provided through the Southern Pine Marketing Council, sponsored by the Southern Forest Products Association (SFPA) and the Southeastern Lumber Manufacturers Association, and through the Southern Region of the Forest Service (Region 8). The Forest Products Laboratory and the Forest Service acknowledge the assistance of the staff at SFPA and the Southern Region in preparing this report.

Contents

	<i>Page</i>		<i>Page</i>
Introduction	1	Weathering of Wood	19
Health and Environmental Considerations	1	Steps in Weathering	19
Lead-Based Paint	1	Rate of Weathering	20
Volatile Organic Compounds	3	Surface Deterioration	21
Wood Properties and		Wood-Based Materials	21
Finish Durability	4	Artificial Weathering	22
Natural Characteristics	4	Precautions for Weathering Wood	22
Density	4	Moisture-Excluding	
Earlywood and Latewood	4	Effectiveness of Finishes	22
Texture	4	Types of Exterior Wood	
Compression Wood	5	Finishes	24
Heartwood and Sapwood	5	Opaque Finishes	24
Extractives, Pitch, and Oils	6	Paint	24
Manufacturing Characteristics	7	Solid-Color Stains	24
Ring Orientation	7	Natural Finishes	28
Surface Texture	7	Water-Repellent Preservatives	28
Knots and Other Irregularities	7	Oils	30
Moisture Content	8	Semitransparent Penetrating Stains	30
Finishing Characteristics	9	Transparent Film-Forming Coatings	31
Construction Practices	9	Fire-Retardant Coatings	33
Control of Moisture Content	9	Application of Exterior	
Installation of Siding	12	Wood Finishes	33
Lumber Siding	12	Opaque Finishes	33
Plywood and Other Sheet Siding	14	Paint	33
Installation Over Rigid Foam Insulation	14	Solid-Color Stains	35
Wood Products Used		Natural Finishes	35
Outdoors	14	Water-Repellent Preservatives	35
Lumber	14	Oils	35
Plywood	15	Semitransparent Penetrating Stains	35
Reconstituted Wood Products	16	Transparent Film-Forming Coatings	36
Treated Wood Products	17	Special Applications	36
Fire Retardants and Fire-Retardant		Decks and Porches	37
Coatings for Wood	18	Fences	37

Contents (continued)

	<i>Page</i>		<i>Page</i>
Roofs	38	Intercoat Peeling	48
Log Structures	41	Cross-Grain Cracking	48
Structures in Marine Environments	42	Blistering	48
Treated Wood	43	Temperature Blisters	48
Preservatives	43	Moisture Blisters	49
Fire-Retardant Treatments	44	Discoloration	49
Refinishing of Wood	44	Diffused Discoloration	50
Opaque Finishes	44	Streaked Discoloration	50
Natural Finishes	45	Wax Bleed	50
Water-Repellent Preservatives	45	Chalking	50
Oils	45	Exudation of Pitch	51
Semitransparent Penetrating Stains	45	Stains	51
Transparent Film-Forming Coatings	45	Iron Stains	51
Removal of Finish	45	Blue Stain	52
Sanding	46	Brown Stain Over Knots	53
Wet Sandblasting and Pressurized		Water Stain	53
Water Spray	46	Sources of Information on Exterior	
Heat	46	Wood Finishing	54
Chemicals	46	Caution	55
Failure or Discoloration of Finish	46	Appendix A	55
Mildew	46	Appendix B	56
Effect of Paint Makeup	47	Consumer Information	56
Prevention and Removal	47	Use Site Precautions	56
Peeling and Cracking	48	Handling Precautions	56

Introduction

The abundance and versatility of wood have generated the extensive use of wood products in North America. The unique characteristics of wood make it suitable for many applications. For the most part, knowledge about these characteristics has been learned through practical experience rather than through scientific investigation.

As virgin timber was cut and used by early settlers in the United States, another forest was growing. Wood cut from this second-growth, or in some cases third-growth, forest varies somewhat from the wood cut from virgin growth. Nevertheless, if properly used and maintained, the younger forest can provide economical building material that, unlike many other resources, can be renewed for future generations. Furthermore, a minimal amount of energy is consumed during the manufacturing process. Once in place, wood continues to conserve energy, for it is a good natural insulator.

A variety of finishes can be applied to wood. These finishes include clear finishes, which reveal and accentuate the natural beauty of wood; stains, which impart a rustic appearance; and paint, which can be obtained in a multitude of colors.

The availability of wood species varies somewhat by regions within the United States. Climatic conditions also vary tremendously—hot, humid climates cause the most rapid deterioration of wood products and finishing systems. Consequently, construction practices, finish formulations, and durabilities also vary. This report has been prepared with special consideration for the southeastern region of the United States.

This report describes the characteristics of wood finishes and their proper application to solid and reconstituted wood products. It describes how manufacturing and construction practices affect the surfaces of wood products, how various types of finishes interact with the surface, and how weathering affects the finished surfaces. Methods for selecting and applying various exterior wood finishes are presented. Finally, the failure and discoloration of wood finishes are discussed, and methods are given for preventing these problems.

Health and Environmental Considerations

Some finishing formulations used in the past and others that are still being manufactured and used are considered hazardous to health and the environment.

Research on the toxicity of finishes is ongoing, and finishing formulations are in the process of change. Therefore, it is important to seek the most current information available when choosing a finish.

Lead-Based Paint

The information in this section is taken from material prepared by the National Association of Home Builders (NAHB) and is contained in *New Life for Old Dwellings*, Agriculture Handbook 481, which is in press.

Lead-based paint was widely used in residential applications in the United States until the early 1940s, and its use was continued to some extent, particularly for the exterior of dwellings, until 1976. In 1971, Congress passed the Lead-Based Paint Poisoning Prevention Act, and in 1976, the Consumer Product Safety Commission (CPSC) issued a ruling under this Act that limited the lead content of paint used in residential dwellings, toys, and furniture to 0.06 percent.

Lead-based paint is still manufactured today for applications not covered by the CPSC ruling, such as paint for metal products, particularly those made of steel. Occasionally, such lead-based paint (for example, surplus paint from a shipyard) inadvertently gets into retail stores and the hands of consumers. A study conducted for the Environmental Protection Agency in 1986 indicated that about 42 million U.S. homes still contain interior and/or exterior lead-based paint. As rehabilitation of these homes increases, how to abate the toxicity of lead-based paint has become the subject of increased public and official concern.

Studies have shown that ingestion of even minute amounts of lead can have serious effects on health, including hypertension, fetal injury, and damage to the brain, kidneys, and red blood cells. Low levels of ingestion can also cause partial loss of hearing, impairment of mental development and IQ, growth retardation, inhibited metabolism of Vitamin D, and disturbances in blood formation. The American Academy of Pediatrics regards lead as one of the foremost toxicological dangers to children.

Lead-based paint applied to the exterior of homes disintegrates into chalk and powder as a result of the effects of moisture and ultraviolet radiation. This extremely fine lead dust can accumulate in the soil near the house and can ultimately enter the house. Poor quality lead-based paint used on interior surfaces can also produce dust. Lead dust can be generated when coatings on surfaces are broken through aging or as a result of rehabilitation. The dust cannot be completely removed by conventional house-cleaning methods.

Table I—Advantages and disadvantages of strategies for abating the toxicity of lead-based paint

Abatement strategy	Advantage	Disadvantage
Replacement	Upgrade of finish possible Permanent solution Low risk of failure to meet clearance standards	Replacement possibly lower in quality than original component Creation of hazardous waste Skilled labor required for installation
Encapsulation	Minimal generation of dust Rapid installation	Protection possibly limited to short term Routine inspection required Expert installation required for product durability Routine maintenance possibly required
Onsite paint removal	Restoration possible Low level of skill required	High generation of dust Difficult-to-remove lead residue left on substrate Moderate risk of failure to meet clearance standards and to protect workers Use of hazardous stripping agents
Offsite paint removal	Restoration possible Finished product generally superior to that produced by onsite paint removal	Difficult-to-remove lead residue left on substrate Potential damage to product during removal from site and reinstallation

The methods used to abate the toxicity of lead-based paint or to remove the paint can themselves generate lead dust. This is particularly true when unacceptable methods and work practices are used. Poorly performed abatement can be worse than no abatement at all. The micron-size lead dust particles can remain airborne for substantial periods and cannot be fully removed by standard cleaning methods from the surfaces on which they have settled. When working on old painted surfaces, the worker should assume that one or more of the paint coats contain lead. Proper precautions should be taken accordingly.

Paint coats may be checked for lead content. A portable x-ray fluorescence (XRF) analyzer is commonly used to determine the level of lead in paint. Because this device has the potential for giving very inaccurate results if used by an inexperienced person, the analysis should be done by a qualified professional. Chemical spot testing, using a solution of 6 to 8 percent sodium sulfide in water, is sometimes used to screen painted surfaces for the presence of lead. Be certain to check all paint coats as the older ones are more likely to be lead based. A kit for detecting lead-based paint is available from the Civil Engineering Laboratory, Naval Construction Battalion Center, Port Hueneme, CA 93043.

The removal of lead-based paints can present some serious health problems. The Department of Health and Urban Development (HUD) has taken a leading

role in developing guidelines for the removal of lead-based paints. At this time, HUD has approved three approaches to abating the toxicity of lead-based paint:

1. Covering the painted surface with wallboard, a fiberglass cloth barrier, or permanently attached wallpaper
2. Removing the paint by scraping or heat treatment
3. Replacing the entire surface to which lead-based paint has been applied

Different strategies for abating the toxicity of lead-based paint are described in Tables 1 and 2. Certain practices are prohibited in houses owned and operated by HUD: machine sanding without an attached high-efficiency particulate air (HEPA) vacuum filtration apparatus, use of propane torches, contained waterblasting, washing, or repainting.

Removal of lead-based paint by scraping or application of heat does not solve the problem of lead-particulate dust. Scraping should be accompanied by misting. Dry scraping is prohibited by Maryland abatement regulations. Sanding without a HEPA-filtered vacuum should not be used as a finishing method after scraping or any other method of toxicity abatement. The H EPA sanders are recommended for limited surface areas only; they are most appropriate for flat surfaces such as door jambs and stair risers. Open abrasive blasting is also prohibited by some regulations. For limited

Table 2--Applications for strategies for abating the toxicity of lead-based paint

Abatement strategy	Appropriate application	Inappropriate application
Replacement	Exterior and interior components Substitution for deteriorated component Windows, doors, and easily removed building components	Restoration projects Most walls, ceilings, and floors When historic trust requirements apply
Encapsulation ^a	Exterior trim, walls, and floors Interior floors, walls, ceilings, and pipes Balustrades	Inappropriateness of encapsulant for substrate and conditions Repainting of leaded surfaces, recovering with contact paper/wallpaper
Onsite paint ^b removal	Limited surface areas Substitution for impractical abatement methods Metal substrates	Large surface areas
Offsite paint ^c removal	Restoration projects, especially doors, mantels, and easily removed trim Metal railings	Some stripping procedures inappropriate for metal

^aDurability essential. Seams must be sealed to prevent escape of lead dust. Safe, effective, and esthetic encapsulant for interior trim components need to be developed and tested.

^bCheck with manufacturer about recommendations for use on various types of wood and metal substrates.

^cCheck with stripping company for timing of work and procedures for neutralizing and washing components.

surface areas, Agriculture Handbook 481 suggests the use of heat-based removal methods or paint strippers.

High levels of airborne lead can be produced by heat guns, and the use of respirators is essential. Some lead is likely to be volatilized at the operating temperatures of most heat guns. Lead fumes are released at about 700°F. (See Appendix A for SI conversion table.) Heat guns capable of reaching or exceeding this temperature should not be operated in that range.

Chemical methods for removing lead-based paint may require multiple applications, depending on the number of paint coats. Caustic and solvent-based chemicals should not be allowed to dry on the lead-painted surface. If drying occurs, paint removal will not be satisfactory, and the potential for creating lead dust will be increased.

Chemical substances used for paint removal are usually hazardous and should be used with great care. Some solvent-based chemical strippers are flammable and require ventilation. They may contain methylene chloride, which is a central nervous system depressant that at high concentrations can cause kidney and liver

damage and is also a possible carcinogen. Supplied air respirators should be used when working with strippers containing this substance. If the solvent-based strippers do not contain methylene chloride, organic vapor filters must be added to respirators. Caustic chemical strippers also have a very high pH (alkaline content), which can cause severe skin and eye injuries.

WARNING: Rehabilitation projects that will require disturbing, removing, or demolishing portions of the structure that are coated with lead-based paint pose serious problems. The home dweller should seek information, advice, and perhaps professional assistance for addressing these problems. Contact HUD for the latest information on the removal of lead-based paints. Debris coated with lead-based paint may be regarded as hazardous waste.

Volatile Organic Compounds

Volatile organic compounds (VOC) are those organic materials in finishes that evaporate as the finish dries or cures. These materials are regarded as air pollutants, and the amount that can be released for a given

amount of solids or coloring pigments in the paints is now regulated in many states. Many new regulations are currently being established. As a result of these regulations, many current wood finishes, including some latex-based materials, may be reformulated. These changes could affect the serviceability of different finishes and perhaps the method in which they are applied. At this time, little information on the long-term performance of these new finishes is available. Such information should be available in the near future.

Wood Properties and Finish Durability

Wood is a natural biological material and as such its properties vary not only from one species to another but within the same species. Some differences can even be expected in boards cut from the same tree. Within a species, factors that affect wood properties, and thus finishing characteristics, are usually related to growth rate. Growth rate in turn is determined by climatic factors, geographic origin, genetics, tree vigor, and competition—factors over which we currently have little control. The natural and manufacturing characteristics of wood are important influences on finishing characteristics and durability. However, most of these characteristics become important only as the finish coat begins to wear.

Natural Characteristics

Density

The properties of wood that vary greatly from species to species are density, grain characteristics (presence of earlywood and latewood), texture (hardwood or softwood), presence of compression wood, presence and amount of heartwood or sapwood, and the presence of extractives, resins, and oils. The density of wood, or its “weight,” is one of the most important factors that affect finishing characteristics. Density varies tremendously from species to species (Table 3), and it is important because “heavy” woods shrink and swell more than do “light” woods. This dimensional change in lumber and, to a lesser extent, in reconstituted wood products and plywood occurs as wood, particularly in exterior applications, gains or loses moisture with changes in the relative humidity and from periodic wetting caused by rain and dew. Wood in heated homes tends to dry and shrink in the fall and winter as a result of low relative humidity, then gain moisture and swell in the spring and summer. Excessive dimensional change in wood constantly stresses a film-forming finish such as paint and may result in early failure of the finish.

The amount of warping and checking that occurs as wood changes dimensions and during the natural weathering process is also directly related to wood density. Cupping is probably the most common form of warp. Cupping is the distortion of a board that causes a deviation from flatness across the width of the piece. Wide boards cup more than do narrow boards. Boards may also twist from one end to the other, deviating from a straight line along the length of the piece. This form of warp is called crook. Warping is generally caused by uneven shrinking or swelling within the board. Furthermore, checks, or small ruptures along the grain of the piece, may develop from stress setup during the drying process or from stresses caused by the alternate shrinking and swelling that occurs during service. High density (heavy) woods such as southern yellow pine tend to warp and check more than do the low density (light) woods such as redwood (Table 3). Finally, low density woods are generally easier to nail, machine, and handle than are high density woods.

Earlywood and Latewood

The presence and amount of latewood (Fig. 1) in softwood (conifer) lumber affect paint durability and are closely related to wood density. Each year, most tree species add one growth increment or ring to their diameter. For most species, this ring shows two distinct periods of growth and therefore two bands, called earlywood (springwood) and latewood (summerwood). Latewood is denser, harder, smoother, and darker than earlywood, and its cells have thicker walls and smaller cavities. The wider the latewood band, the denser the wood. New paint adheres firmly to both earlywood and latewood. However, old paint that has become brittle with age and weathering loses its adhesion and peels from the smooth, hard surface of the latewood. With varnishes, initial failure occurs over the earlywood as a result of ultraviolet radiation degradation of the varnish-wood interface. If the bands of latewood are narrow enough, as in slow growth trees, the coating may bridge the latewood and remain in place longer than it does on the wider latewood bands. Wide latewood bands are normally absent from edge-grained cedar and redwood, improving the paintability of these species. However, they are prominent in southern yellow pine and Douglas-fir, two of the most common species used for general construction and for the production of plywood. On the other hand, growth rate does not seem to significantly affect the ability of hardwoods to retain a paint coat.

Texture

Texture refers to the general coarseness of the individual wood cells and is often used in reference to hardwoods (Fig. 2). Hardwoods are primarily com-

Table 3--Characteristics of selected solid woods for painting and finishing

Wood	Density (lb/ft ³) at 8 percent moisture content ^a	Paint-holding characteristic (I, best; V, worst) ^b	Resistance to cupping (1, most; 4, least)	Conspicuousness of checking (1, least; 2, most)	Color of heartwood	Degree of figure on flat-grained surface
Softwoods						
Western redcedar	22.4	I	1	1	Brown	Distinct
Cypress	31.4	I	1	1	Light brown	Strong
Redwood	27.4	I	1	1	Dark brown	Distinct
Eastern white pine	24.2	II	2	2	Cream	Faint
Ponderosa pine	27.5	III	2	2	Cream	Distinct
White fir	25.8	III	2	2	White	Faint
Western hemlock	28.7	III	2	2	Pale brown	Faint
Spruce	26.8	III	2	2	White	Faint
Douglas-fir ^c	31.0	IV	2	2	Pale red	Strong
Southern yellow pine ^c	38.2	IV	2	2	Light brown	Strong
Hardwoods						
Eastern cottonwood	28.0	III	4	2	White	Faint
Magnolia	34.4	III	2	--	Pale brown	Faint
Yellow-poplar	29.2	III	2	1	Pale brown	Faint
Lauan (plywood)		IV	2	2	Brown	Faint
Yellow birch	42.4	IV	4	2	Light brown	Faint
Gum	35.5	IV	4	2	Brown	Faint
Sycamore	34.7	IV	--	--	Pale brown	Faint
American elm	35.5	V or III	4	2	Brown	Distinct
White oak	45.6	V or IV	4	2	Brown	Distinct
Northern red oak	42.5	V or IV	4	2	Brown	Distinct

^a 1 lb/ft³ = 16.02 kg/m³.

^b Woods ranked in group V are hardwoods with large pores, which require wood filler for durable painting. When the pores are properly filled before painting, group II applies.

^c Lumber and plywood.

posed of relatively short, small-diameter cells (fibers) and large-diameter pores (vessels); softwoods, in contrast, are composed of longer small-diameter cells (tracheids). The size and arrangement of the pores may outweigh the factors of density and grain pattern in their effect on paint retention. Hardwoods with large pores, such as oak and ash, are poorly adapted to ordinary housepainting methods because pinholes can form in the coating over the large pores. Pinholes are unsightly and lead to early failure of the coating. On the other hand, yellow-poplar has a relatively uniform, fine texture free of large pores, which improves its overall paintability in comparison to the coarse-textured species.

Compression Wood

Compression wood is formed on the lower side of leaning softwood trees. The part of the growth ring with

compression wood is usually wider than the rest of the ring and has a high proportion of latewood. As a result, the tree develops an eccentrically shaped stem and the pith is not centered. Compression wood, especially the latewood, is usually duller and more lifeless in appearance than the rest of the wood. Compression wood presents serious problems in wood manufacturing because it is much lower in strength than is normal wood of the same density. Also, it tends to shrink excessively in the longitudinal direction, which causes cross-grain checking.

Heartwood and Sapwood

As trees mature, most species naturally develop a darker central column of wood called heartwood. To the outside of the heartwood is a lighter cylinder of wood called sapwood. The sapwood is composed of live cells that serve to transport water and nutrients

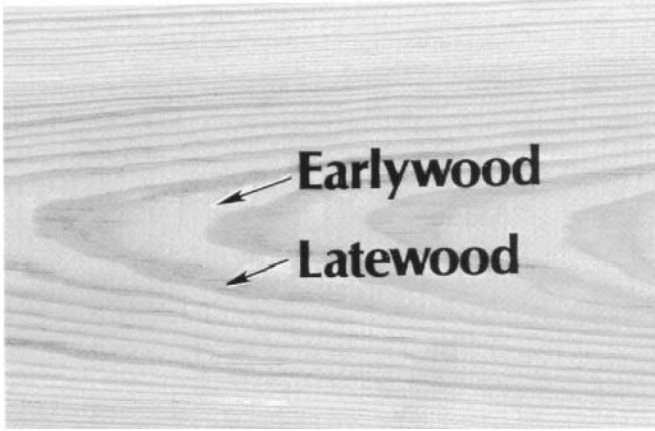

Figure 1—Earlywood and latewood bands in southern yellow pine. Because these distinct bands often lead to early paint failure, penetrating stains are preferable for finishing this kind of wood.

from the roots to the leaves and to provide mechanical support for the tree. The heartwood, on the other hand, serves only as support. Heartwood is formed as the individual cells die and are impregnated with extractives, pitch, oil, and other extraneous materials. Older trees have a higher percentage of heartwood as compared to younger trees. Some species such as southern yellow pine have a much wider sapwood zone than do species like the cedars and redwood.

The old-growth timber from some species, such as cypress, is notable for its natural resistance to decay and insects. The second-growth timber contains a higher percentage of sapwood, which has no resis-

tance to decay and insects; its heartwood is not as resistant as that of old-growth timber.

Extractives, Pitch, and Oils

Depending on species, wood may contain water-soluble extractives, pitch, or oil. Each of these substances has its own properties and characteristics. Although these substances constitute only a small percentage of the oven-dry weight of wood, they affect, to some degree, many wood properties including color, odor, decay and insect resistance, permeability, density, and hardness. The deposition of these substances is generally associated with the formation of heartwood. Without extractives, pitch, and oil, many woods would appear essentially identical except for their anatomical features.

Water-soluble extractives are extraneous materials that are naturally deposited in the lumens, or cavities, of cells in the heartwood of both softwoods and hardwoods. They are particularly abundant in those woods commonly used for exterior applications, such as western redcedar, redwood, and cypress, and are also found in lesser amounts in Douglas-fir and southern yellow pine where heartwood is present. The attractive color, good dimensional stability, and natural decay resistance of many species are due to the presence of extractives. However, these same extractives can cause serious finishing defects both at the time of finish application as well as later. Because the extractives are water soluble, they can be dissolved when free water is present and subsequently transported to the wood surface. When this solution of extractives

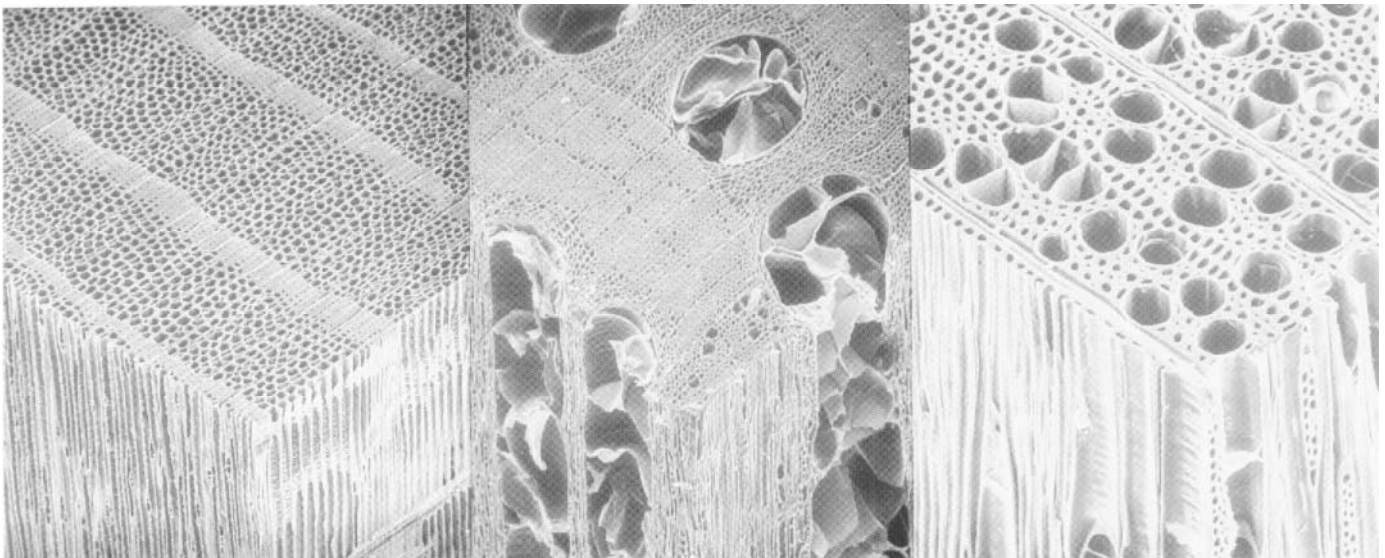

Figure 2—Left, nonporous wood (softwood or conifer such as southern yellow pine); center, ring-porous (white oak); right, diffuse-porous (yellow-poplar).

reaches the painted surface, the water evaporates, and the extractives remain as a reddish-brown mark. This reddish-brown mark is particularly noticeable on white or very light-colored paints or solid-colored stains.

Pitch in most pines and Douglas-fir can be exuded from either the sapwood or heartwood. Pitch is usually a mixture of rosin and turpentine; this mixture is called resin. Rosin is brittle and remains solid at most normal temperatures. Turpentine, on the other hand, is volatile even at relatively low temperatures. By use of the proper kiln-drying techniques, turpentine can generally be driven from the wood, leaving behind only the solid rosin. However, for green lumber or even dried lumber marketed for general construction, different kiln schedules may be used, and the turpentine remains in the wood, mixed with the rosin. The resultant resin melts at a much lower temperature than does pure rosin, and consequently the mixture can move to the surface. If the surface is finished, the resin may exude through the coating or cause it to discolor or blister. This problem usually develops slowly as the air located in the resin ducts and cell lumens shrinks and expands as a result of temperature changes and forces the resin outward. The most serious problems occur when wood is heated; for example, when the sun strikes the south side of a house. Once the sticky resin is on the surface of the wood, the turpentine evaporates, leaving beads of hard rosin. If the wood is painted, the resin will diffuse through the paint coats, discoloring them.

Aromatic oils are present in some woods such as cypress, teak, and the cedars (except western redcedar) and can cause finishing problems. These oils are mixtures of liquids or solids that are difficult to crystallize. They are soluble in many common finishing films and thus may discolor the paint or other finish. The presence of oils may also retard drying of coatings, leaving them sticky, and often cause blistering, softening, wrinkling, and general disintegration of the coatings.

Some oils have high boiling points and evaporate only very slowly, even at the temperatures used to kiln-dry wood. Finishing problems with pitch and oils can generally be reduced through the use of the correct kiln-drying schedules. However, some care must be exercised not to carry the oil reduction process too far if an aromatic odor in the finished product is desirable.

White or light-colored paint occasionally may acquire a yellow or brown discoloration on the heartwood of ponderosa pine and the white pines. The discoloration generally begins immediately over the resin passages. Later, it may diffuse throughout the coating over the heartwood, leaving the sapwood area unaffected. The

color comes from substances in the resin of the heartwood and usually occurs on wood that is damp while being painted. It rarely occurs on dry wood. Because the discoloration fades with sunlight, it is less of a problem with exterior woodwork.

Manufacturing Characteristics

Some characteristics of wood, such as how the board was sawn from the log (which determines growth ring orientation), the presence of knots and similar irregularities (lumber grade), and moisture content, are determined primarily during the manufacturing, grading, and distributing processes. These processes can affect the finishing characteristics and durability of solid wood products.

Ring Orientation

The manner in which a board is cut from a log affects the orientation of the annual rings in the piece and thus its paintability. Softwood lumber is referred to as either flat grained or edge grained (plainsawed or quarter-sawed in hardwoods) or a combination of the two (Fig. 3). Most standard lumber grades contain a high percentage of flat grain. Lumber used for board and batten siding and shiplap is frequently flat grained. Bevel siding of redwood or cedar is generally produced in a flat-grained standard grade and an edge-grained premium grade. Flat-grained lumber shrinks and swells more than does edge-grained lumber and also has wider, darker bands of latewood. Therefore, edge-grained lumber for siding will usually hold paint better than does flat-grained material. Quartersawed hardwood boards hold paint better than do plainsawed boards, but the difference is relatively small compared to the difference between quartersawed and plainsawed softwoods.

Surface Texture

Lumber may be left in its roughsawn condition or surfaced smooth after drying. Paint will last longer on smooth, edge-grained surfaces. Natural finishes such as penetrating stains or preservative treatments are preferred for roughsawn and flat-grained lumber. The natural finishes often accentuate the rustic look of roughsawn lumber and allow the wood grain and surface texture to show through the finish. On plywood, paint will last longer on new, rough-textured surfaces than on smooth surfaces because more paint can be applied to the rough surface.

Knots and Other Irregularities

The presence of knots and other irregularities (such as bark, splits, pitch pockets, and insect damage) affects the paintability of lumber and is generally a function of

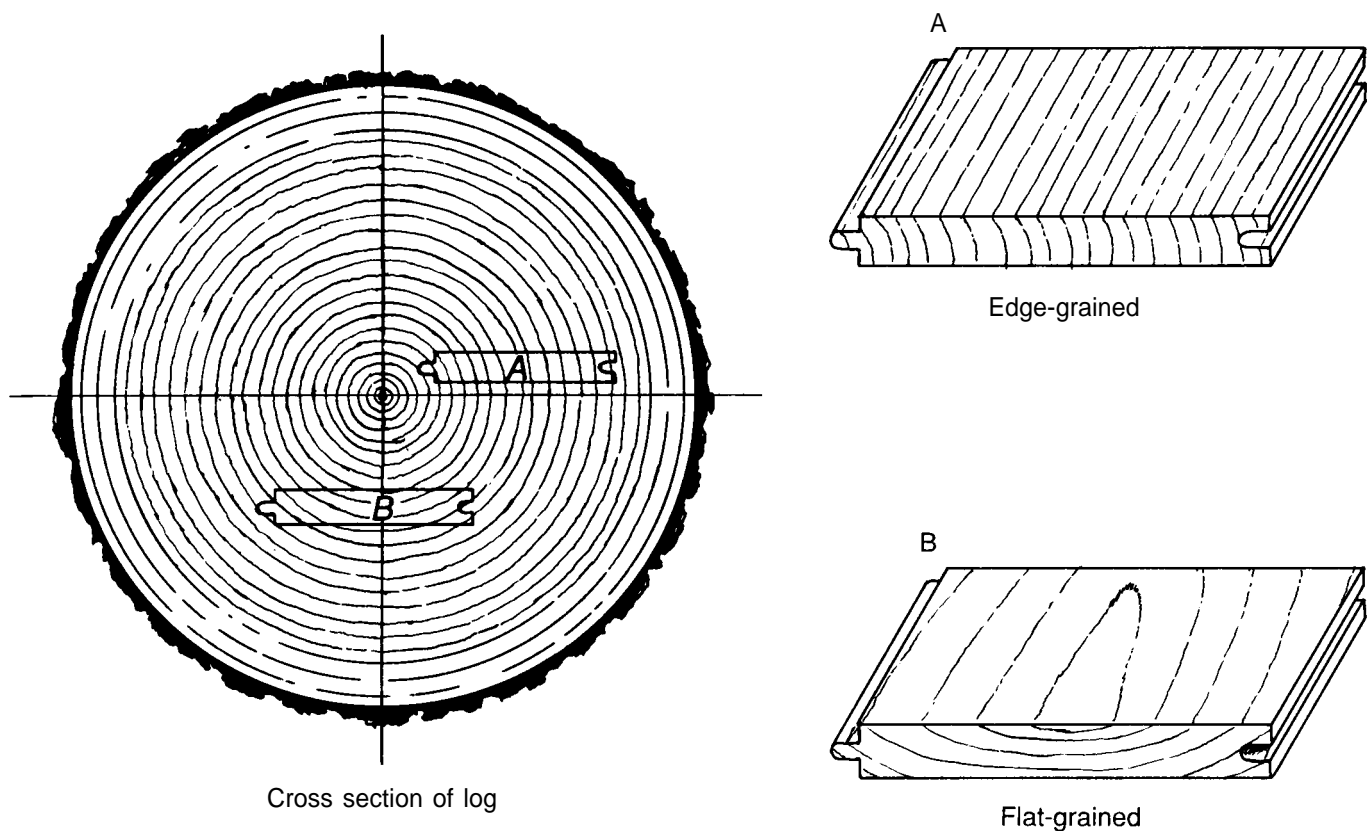

Figure 3-Effect of sawing method on ring orientation in lumber. (M 148 631)

lumber grade. Knots are mostly exposed end-grain. End-grained wood absorbs more finish than does flat- and edge-grained lumber, and this affects the appearance of the paint coating. In pine, knots often contain a high percentage of resin, which may cause the paint over the knot to discolor. Furthermore, large knots usually check and crack to the extent that a noticeable split or defect can result. Therefore, the higher grades of lumber intended for finishing are generally preferable for achieving maximum serviceability of a paint coat.

Moisture Content

Finally, the moisture content of the wood is a critical factor in determining the service life of paint. Fortunately, the moisture content of lumber can be controlled with a little effort, but all too often this critical factor is forgotten during the construction and finishing process. The best time to paint wood is when its average moisture content is about that expected to prevail during service. Ideally, wood is installed at this average moisture content. The moisture content and thus the dimensions of the piece will still fluctuate somewhat, depending on atmospheric relative humidity, but the change will not be excessive in either direction. Therefore, film-forming finishes (such as paints) will not be stressed unnecessarily, and a long service life can be expected.

The recommended moisture content for wood used in exterior applications varies substantially depending on geographic region (Table 4). In the South, higher moisture content values than those shown in the table have been experienced depending on local conditions, including elevation. However, problems associated with the loss or gain of moisture should be minimized if the moisture content is between 9 and 14 percent. Most lumber is kiln dried to acceptable or a somewhat higher moisture content before shipment. Material that has been kept dry during shipment and storage at the construction site should have the desired moisture content.

Lumber that is marketed for construction purposes in the kiln-dried condition but is obviously wet and sometimes discolored should be rejected. If the material is used, it will dry in service, but shrinkage and accompanying warping, twisting, and checking will likely occur.

If the moisture content of the wood exceeds 20 percent when it is painted, blistering and peeling are likely. Moreover, the dark water-soluble extractives in woods like redwood and western redcedar may discolor the paint shortly after it is applied.

Plywood, particleboard, hardboard, and other extensively processed wood products undergo a significant

change in hygroscopicity during manufacture. Frequently, the desired equilibrium moisture content (the moisture content to which a wood product will condition itself, depending on the relative humidity of the surrounding air) of such materials is not known and may vary depending on the manufacturing process. Extensively processed wood products should be conditioned to the average relative humidity in the area. It is not necessarily desirable that these products be conditioned to the same moisture content as that of lumber.

Finishing Characteristics

The paintability of various softwoods and hardwoods used in the southeastern part of the United States is described in Table 3 in terms of the natural wood characteristics of density, presence of latewood, and texture, and of manufacturing characteristics such as ring orientation. This table also provides information on cupping, checking, color of heartwood, and degree of figure. Of the softwoods, redwood and western redcedar are rated the easiest to finish and maintain (group I), whereas southern yellow pine and Douglas-fir are rated difficult to finish and maintain (group IV). Redwood and cedar are low density woods and have narrow bands of latewood, whereas southern yellow pine and Douglas-fir are higher in density and have wide bands of latewood. The best hardwoods for painting are fine, uniform-textured (small-pored) woods with medium to low density such as yellow-poplar, magnolia, and cottonwood. These group III hardwoods should perform as well as softwoods in group III and IV because the hardwoods have less tendency to split and do not have distinct latewood bands, which can separate, at least in part, from the earlywood bands. The result is a raised grain or "shell-out" effect. The group IV hardwoods can be painted using standard procedures, and the service life of the finish will be only a year or so shorter than that of group III hardwoods. However, repainting may be difficult unless all old paint is removed first. On hardwoods, paint tends to scale off in rather large flakes, apparently regardless of the grain of the wood beneath the paint. The pores of the group V hardwoods are so large that they are not filled and leveled off properly by ordinary house paint. The pores consequently become the foci for early paint failure. Therefore, the pores must be filled with wood-filler paste prior to painting.

When group IV and V hardwoods are exposed to the weather without paint or with inadequate paint protection, or when water enters behind the wood, the wood has a marked tendency to warp or cup and pull away from fastenings. These hardwoods need to be nailed firmly, although such nailing may cause the boards to split. Thinner boards are more likely to cup or warp from surface wetting and drying than thicker boards.

Table 4--Recommended average moisture content values at time of installation for wood used in exterior applications such as siding and wood trim

Geographical area	Moisture content (percent)	
	Average	Individual pieces
Most areas of United States	12	9-14
Dry southwestern areas	9	7-12
Warm, humid coastal areas	12	9-14

For these reasons, 1/2-in. siding of heavy hardwoods is impractical. Boards for exterior exposure should be no thinner than 3/4 in. at any point and preferably less than 6 in. wide.

Where group III and IV hardwoods are used for exterior coverings of buildings, thick, rough (unplaned) boards, well-nailed with corrosion-resistant nails, will give the best performance. If the wood is left to weather naturally, it will mildew. Mildew occurs more rapidly and is more extensive in warm, moist climates common in the South. For these groups of hardwoods, certain measures should be taken prior to finishing, and finishes other than paint should be applied:

1. For maximum weather tightness, use full-length, vertical tongue-and-groove siding, dip-treated in a water-repellent preservative and installed bark-side out. All lumber should be accurately milled.
2. For good performance and ease of refinishing, use semitransparent penetrating stains. These stains will perform better on roughsawn boards than on new, smooth wood. Semitransparent stains cannot be used over painted surfaces.

Construction Practices

In addition to choosing the most cost-effective wood product and compatible finish for a particular application, it is important to follow proper construction practices during installation. In this section, we will discuss good construction practices for controlling moisture content in the structure and for installing siding.

Control of Moisture Content

Moisture content is critical in determining finish performance both at the time of installation and during the

entire life of the structure. It is also critical in preventing decay and insect attack. In some cases, excessive moisture content can render a house uninhabitable because the resultant mold and decay fungi produce allergic reactions in the inhabitants,

The following construction features help minimize moisture damage to the structure and thus to the outside paint coat or finish (Fig. 4):

1. Wide roof overhangs provide some protection from sun and rain to at least the upper portions of the structure. When a 4-ft-wide overhang is provided, approximately two-thirds of a conventional one-story sidewall is protected from exposure to full sunlight.
2. Metal flashings under shingles at roof edges prevent water from entering the roof decking and sidewalls, particularly on roofs with a low slope that are located in areas of high rainfall.
3. Metal flashings in roof valleys, junctions of roofs and walls, along dormers and siding material changes, and around chimneys, as well as drip caps over window and door frames, help prevent water from entering the house.
4. Adequate and properly maintained gutters and properly hung downspouts prevent overflow and subsequent wetting of house eaves and sides and resulting "rainwater splash" of the siding near ground level (Fig. 5).
5. Adequate insulation and ventilation of attics and crawlspaces prevents moisture condensation and

resulting high moisture contents in the remainder of the house.¹

6. Exhaust fans should be used to remove moisture from high-humidity areas such as washrooms with showers or baths and kitchen areas. Be sure the fans are vented to the outside of the house. Clothes dryers should never be vented to the inside living quarters or to the crawlspace, basement, or attic. Plumbing should be well maintained.
7. If the house is built on a crawlspace, a clearance of at least 18 in. between the soil and the floor joists is required. The ground should be covered with a 6-mil polyethylene sheet or soil cover to prevent moisture movement from the soil upward. The crawlspace should be adequately ventilated and the vents kept open except in the coldest weather.
8. Any wood used for siding, sheathing, or plates should be at least 8 in. (above the outside groundline unless pressure treated with a wood preservative).
9. Proper installation of vapor barriers (vapor retarders), where appropriate, will help minimize condensation in walls and ceilings.

Visible or concealed condensation in walls and ceilings can cause problems that range from mold and paint failure to decay, structural damage caused by decay, and loss of thermal resistance for any insulation

¹Sherwood, Gerald E. and Robert E. Stroh. wood-frame house construction. Agric. Handb. 73. Washington, DC: U.S. Department of Agriculture; 1989 (rev.). 260p.

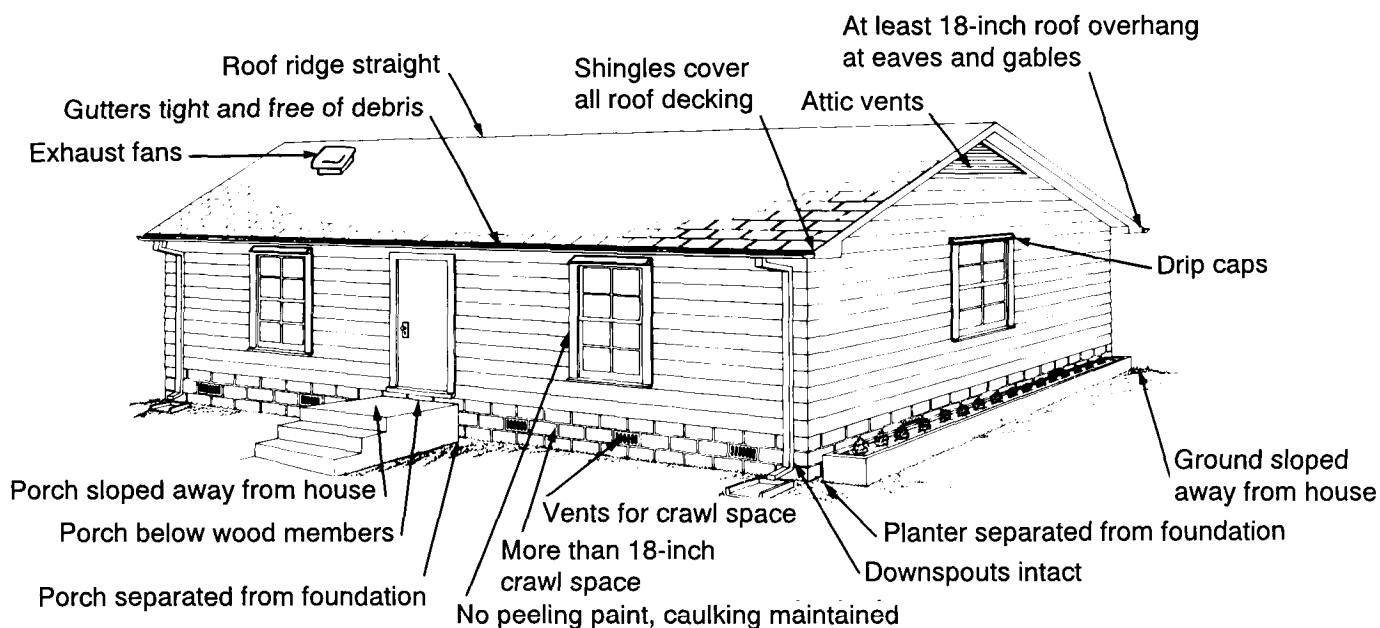

Figure 4-Good construction practices prevent excessive buildup of moisture in wood members. Maintaining the correct moisture contents in wood increases the service life of finishes and decreases the risk of wood decay. (M84 0514)

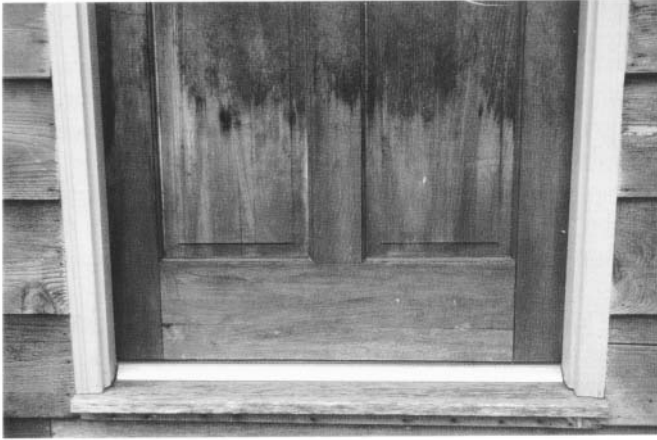

Figure 5-Rainwater splash on entrance door and siding. Rain water runs from the roof and wets the siding as it hits the concrete step.

present. Vapor retarders were originally designed to keep water vapor out of walls and roofs to prevent or at least minimize condensation and moisture damage from moisture diffusion through the wall. The concept of vapor retarders is approximately 50 years old. However, a detailed discussion is provided here since vapor retarders have increased in importance and our understanding of them has improved.

In the 1960s, researchers concluded that the amount of water vapor carried by air currents from air leaks could be much larger than the amount delivered by water vapor diffusion. Many condensation problems in buildings are probably associated with air leaks rather than vapor diffusion. Effective vapor retarders prevent condensation by limiting air flow into the wall or ceiling.

Traditionally, recommendations for vapor retarders have been based on climate. Three different climate zones are recognized in the United States, based on winter design temperatures (Fig. 6). Zone I includes areas with design temperatures below -20°F ; zone II, between 0°F and -20°F ; and zone III, $>0^{\circ}\text{F}$, with the exception of areas with extremely warm and humid summers.

Vapor retarders are traditionally recommended in all exterior walls in zones I and II, and in zone III when the wall is insulated beyond R-4. Ceiling vapor retarders have traditionally been recommended for zone I only, but they are now recommended for zone II as well. These recommendations conform with current interim guidelines from the American Society of Heating, Refrigerating, and Air Conditioning Engineers.²

Polyethylene is the most commonly used vapor retarder. A thickness of at least 4 mils, and preferably

more than 4 mils, is recommended. Foil-backed gypsum board may be used as a vapor retarder instead of polyethylene sheets. Blanket-type insulation that has an aluminum or polyethylene vapor retarder attached to one face will also suffice. Kraft-paper backing is less effective as an air barrier or vapor retarder.

The vapor retarder must be continuous, especially if it also functions as the main air barrier in the wall or ceiling. Penetrations, such as electrical outlet boxes, must be carefully sealed. Vapor retarder flanges should be stapled to the front face of the stud, not the side of the stud. Flanges should overlap. Any torn or damaged areas should be repaired.

It is difficult to install vapor retarders in existing buildings without removing the interior finish material or adding a new wall covering. However, certain paints may have some effectiveness as a vapor retarder if applied to the inside surface of exterior walls. Two coats of aluminum paint containing leafing pigment plus two coats of decorative paint are the best for sand-finished plaster. One manufacturer of household paints has determined that two coats of its alkyd semigloss interior paint, which has a dry film thickness of 2.4 mils, has a vapor permeance of 0.9. Latex paints based on butadiene-styrene resins can be used as interior vapor barrier primer paints. However, typical latex paints other than the butadiene-styrene paints have a relatively high vapor permeance and will not effectively retard the movement of moisture through the wall. The vapor permeance for 4-mil polyethylene is 0.08 and for kraft and asphalt building papers, about 0.3. Remember, however, that any gaps in the paint film render it essentially ineffective. Maintaining indoor humidity at a safe level is especially critical when a flueless energy-efficient or electrical furnace is installed and the building becomes more airtight.

In vented or unvented crawlspaces and for floors over unheated basements, blanket insulation with an attached vapor retarder is often used. The vapor retarder is placed face-up towards the warm side of the



Figure 6-Condensation zones in the United States.

²ASHRAE Handbook, Fundamental I-P Addition, 1989. American Society of Heating, Refrigerating, and Air Conditioning Engineers, 1791 Tolu Circle NE, Atlanta, GA 30329.

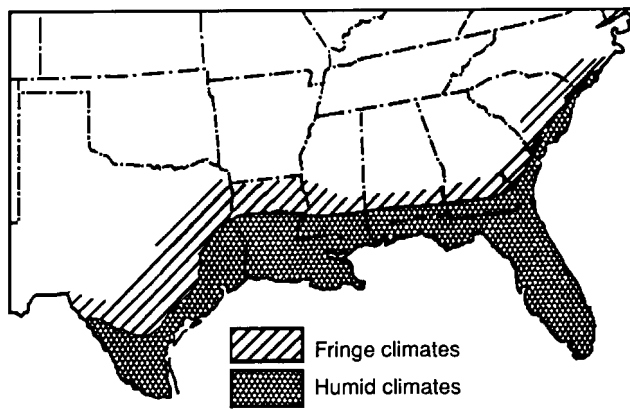

Figure 7—Humid climates in the continental United States follow the coastal belt of the Gulf of Mexico and South Atlantic coastal areas.

crawlspace or floor in cold winter climates. Exposed soil in the crawlspace should be covered with a polyethylene vapor retarder. When floor insulation is applied over a partially heated basement, or the house is located in a warm, humid climate, the vapor retarder may be placed face down.

Summer air cooling for comfort in temperate climates does not usually create serious vapor problems in exterior walls and ceilings. Normally, the cooled air is not much colder than the dewpoint of the outdoor air. Therefore, the vapor retarder should be placed in the best location for preventing winter condensation and summer condensation should be disregarded, even though some condensation may occur during the summer. The cooling system should be properly designed and have the capability for adequate dehumidification of the incoming air without overcooling. Proper maintenance and operation of the air-conditioning system is important.

Humid climates deserve special attention (Fig. 7). Where dwellings are constantly air conditioned, warm moist air can move from the outside and condense on the cooler inside portion of outside walls. This situation is the reverse of cold weather condensation experienced in northern climates, but the same principle applies. The amount of condensation that is likely to occur is difficult to generalize and depends on local conditions. Therefore, successful, trouble-free local practices should be followed. In general, exterior surfaces of the building should be airtight and higher in vapor resistance than interior surfaces, and an interior vapor retarder is not recommended.

Vapor retarders should be used on the outside of exterior walls. Any water that does enter the outside surface of the structure can flow to the inside where it can be removed by the air-conditioning system instead of accumulating in the floor, wall, or roof construction.

Installation of Siding

Good construction practices for installing siding are governed by the type of siding used. These construction practices assume that the lumber and other wood products have been properly stored on-site. For example, the wood has been protected from moisture, accumulation of dirt, and abrasion. It is essential that the wood be kept dry before and during construction.

In the following section, we will describe specifications for installing siding made from lumber and plywood. The section also includes specifications for installing siding over rigid-foam insulation.

Lumber Siding

Wood siding is relatively simple to install. It is precision manufactured to standard sizes in different patterns (Fig. 8) and is easily cut, fitted, and fixed in place with ordinary tools.

Courses of horizontal siding should be spaced so that a single board runs continuously above and below windows and doors without notching or splicing (Fig. 9). Bevel siding that is 6 in. wide should have at least 1 in. of overlap between courses. Siding that is 8 in. or wider should overlap 1 to 1-1/2 in., depending on spacing required between window heights.

Siding should be butted snugly and squarely against door and window casings, corner boards, and adjoining boards. (Corner boards should lie flat against the sheathing.) Mitered corners should also be precisely fitted (Fig. 10). Even if metal corner covers are used, siding boards should be carefully cut to avoid leaving a hollow place in the wood joint where water could collect.

All nailing should be over studs, and the total effective penetration of the nail into the wood should be at least 1-1/2 in. For example, 3/8-in. -thick siding over 3/4-in. wood sheathing requires a sevenpenny (7d) nail, which is 2-1/4 in. long. This combination results in a 1-1/8-in. penetration of the nail into the stud, and a total effective penetration of 1-7/8 in. into the wood. However, nails that are longer than necessary should be avoided because they may interfere with electrical wires and plumbing.

To fasten siding in place, hot-dipped galvanized, aluminum, stainless steel, or other noncorrosive nails are recommended. Aluminum or stainless steel nails are best for naturally finished siding. Plain steel-wire nails, especially the large-headed type that are designed for flush driving, often make unsightly rust spots on most paints. Even small-headed, plain steel-wire

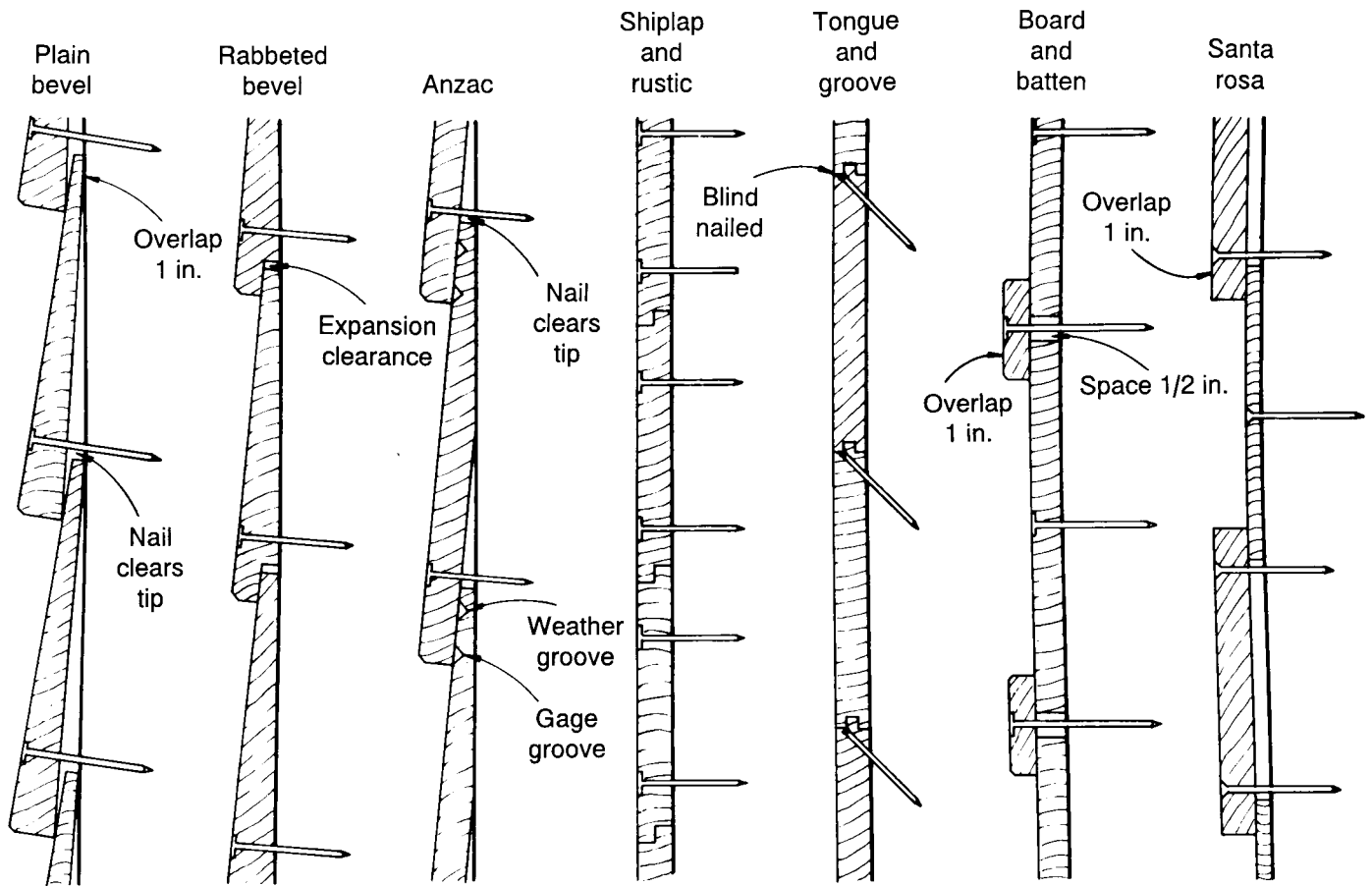

Figure 8—Different siding patterns and recommended nailing methods for various types of wood siding. (M 139 819)

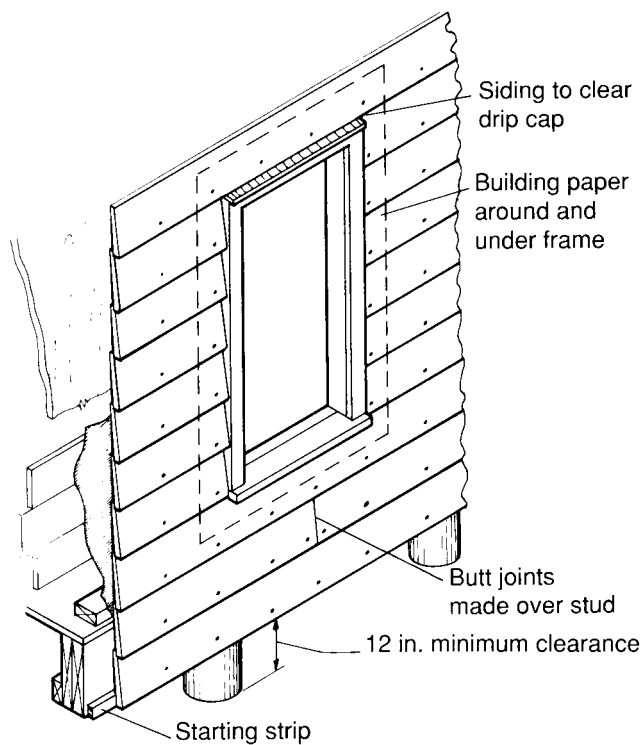

Figure 9—Installation of bevel siding. (ML83 5110)

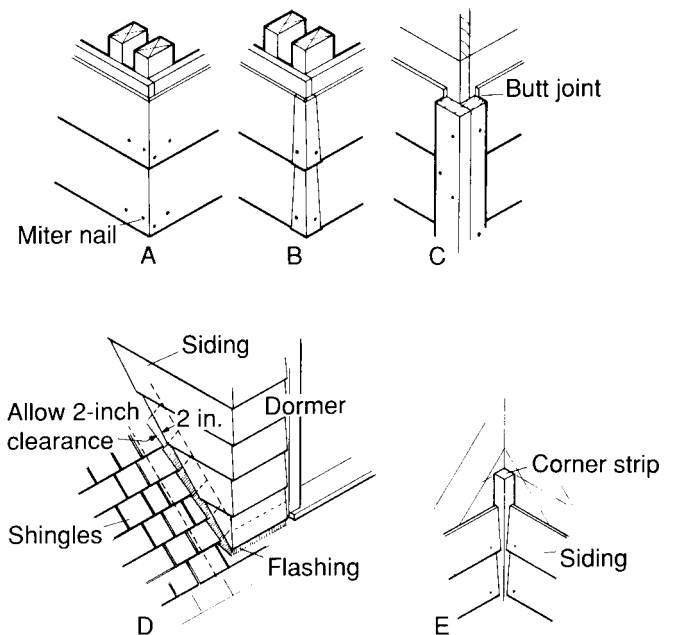

Figure 10—Recommended procedures for corners of siding: (A) miter corner, (B) metal corner, (C) corner boards, (D) siding return at roof, and (E) interior corner. (M 134 776)

nails, countersunk and puttied, are likely to spot the finish with rust eventually.

For best performance, nailing patterns for various kinds of siding and application procedures should comply with the recommendations of the siding manufacturers (Fig. 8). If possible, solid lumber siding should be fastened so that boards are free to shrink and swell, thereby reducing the tensile stresses that develop at the fasteners and often result in cracking and splitting.

For plain bevel patterns, the siding should be face nailed, one nail per bearing, so that the nail clears the edge of the undercourse. Eightpenny or 10d nails are recommended for 1-in.-thick siding and 6d (2 in.) to 8d (2-1/2 in.) nails for thinner material.

Shiplap siding in 4- and 6-in. widths should be face nailed, one nail per bearing, 1 in. from each overlapping edge. One additional nail should be placed in the center of siding boards 8 in. or more in width. Again, 8d nails should be used for 1-in.-thick siding.

Tongue-and-groove siding, 6 in. or less in width, is either face nailed with one 8d nail per bearing or blind-nailed with one 6d finish nail through the tongue. Boards 6 in. or more in width are face nailed with two 8d nails.

In board-and-batten patterns, the underboards are spaced 1/2 in. apart and nailed with one 8d or 9d (2-3/4-in.) siding nail at the center of the board. The batten strip, 1-1/2 in. wide, is nailed at the center with one 10d (3 in.) or 12d (3-1/4-in.) nail. In board-on-board or Santa Rosa siding, the underboard also is nailed with one nail at the center of the board. The outer boards, positioned to lap the underboards by 1 in., are face nailed with two 10d or 12d nails 1-1/4 in. from the edge.

Plywood and Other Sheet Siding

Exterior-grade plywood, paper-overlaid plywood, and similar sheet materials used for siding are usually applied vertically. When used over sheathing, plywood should be at least 1/4 in. thick; 5/16- and 3/8-in.-thick panels will normally provide a more even surface. When used as sheathing and siding, plywood should be at least 1/2-in. thick. Hardboard should be at least 1/4-in. thick, and materials such as medium-density fiberboard should be at least 1/2-in. thick. All types of sheet material should have joints caulked with mastic unless the joints are of the interlapping or matched type or battens are installed. Applying a strip of 15-lb asphalt felt under uncaulked joints is also a good practice. When two or more sheets are applied vertically, metal flashing should be used to protect the top

edge of the lower sheet. The edges should also be treated with a water-repellent preservative.

Plywood should be nailed at 6-in. intervals around the perimeter and 12-in. intervals in the middle. Hardboard siding should be nailed at 4- and 8-in. intervals. Always check the manufacturer's recommendations before installing any panel product.

Installation Over Rigid Foam Insulation

If rigid-foam, gypsum, or non-nail-base fiberboard sheathing is applied under the siding, the nail lengths must be adjusted to account for the sheathing thickness. The same effective nail penetration into solid wood as that used for lumber siding is desirable. Guidelines from the National Forest Products Association address the nailing of wood-bevel siding and hardboard-lap siding over rigid-foam sheathing. For installing 1/2-in. wood-bevel siding over 1/2-in. rigid-foam sheathing, the guidelines recommend a 9d smooth-shank or a 7d ring-shank wood-siding nail. If 3/4-in. rigid-foam sheathing is used, the nail size should be increased to a 10d smooth shank or 8d ring shank. When 3/4-in. wood-bevel siding is installed over 1/2-in. rigid-foam sheathing, the wood-siding nail sizes recommended are 10d smooth shank or 8d ring shank. If 3/4-in. rigid-foam sheathing is used, the nail size should be increased to 12d smooth shank or 9d ring shank. For installing 7/16-in. hardboard lap siding over either 1/2-in. or 3/4-in. (rigid-foam sheathing, a 10d smooth-shank hardboard-siding nail is recommended.

Wood Products Used Outdoors

Three general categories of wood products are commonly used in construction: lumber, plywood, and reconstituted wood products (Fig. 11). Each product has unique characteristics that will affect the durability of any finish applied to it. In addition, any of these products may be treated with wood preservatives or fire-retardant chemicals, some of which also affect the finishing characteristics of the product.

Lumber

Lumber continues to be favored for exterior application. Although this use had declined for several decades, there is currently an increase in the use of solid wood siding, particularly in multi-family units and high value homes.

Bevel siding is perhaps the most popular type of siding for houses. Tongue-and-groove and shiplap patterns are also used (Fig. 8), especially on buildings without sheathing. These patterns of siding are applied

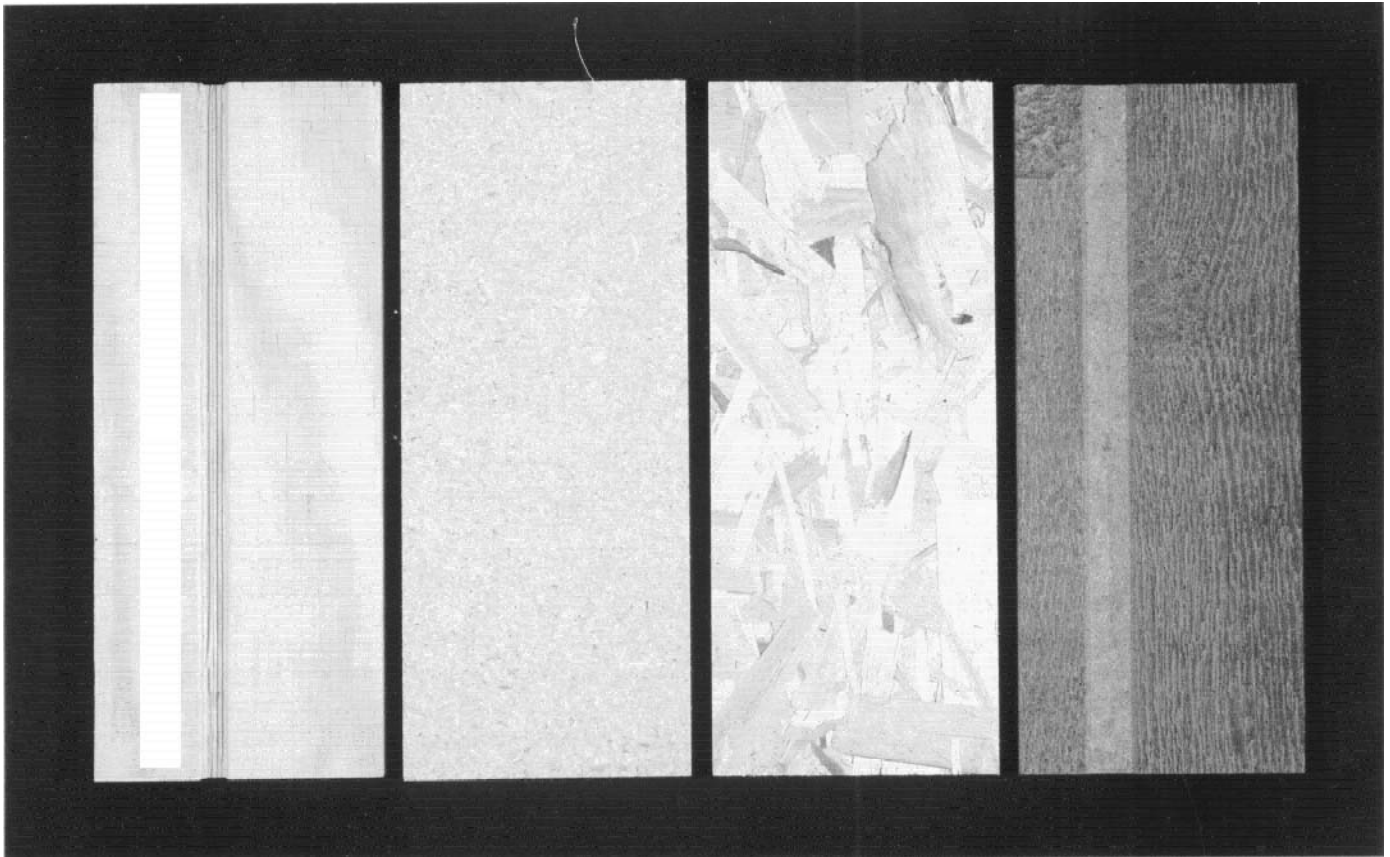

Figure 11—Plywood (left), particleboard, waferboard, and hardboard (right) are manufactured or reconstituted wood products. Special precautions should be taken when painting or staining these products.

horizontally or at an angle and tend to make a structure appear lower and longer.

Vertical siding is increasingly popular. It consists of tongue-and-groove, shiplap, or square-edged boards, which are often applied with narrow strips (battens) over the joints. Vertical siding may also be applied in a Santa Rosa pattern, with the edges of the boards overlapping.

Vertical siding patterns may help to reduce the effects of light and weathering. Water drains better from vertical boards than from horizontal. Vertical siding is also slightly more resistant to sunlight than is beveled horizontal siding because the angle of incident sunlight is smaller and ultraviolet radiation effects are reduced. Therefore, finishes are likely to perform somewhat better on vertical rather than horizontal siding.

Because it is not always cost-effective or even possible to purchase edge-grained, irregularity-free lumber for siding or exterior trim, paying attention to the important characteristics of individual boards before installing them can substantially lengthen the life of a paint coat. A paint coat is generally renewed as it fails on the poorest performing boards. Individual boards with a

flat-grained pattern and wide growth rings that show the darker latewood should be avoided if possible (Fig.12). Dense boards and those with excessive knots or other defects can also cause early paint failure. This material should be used only where appearance is not important or for nonexposed construction, providing the material does not have excessive strength-reducing defects. If these boards must be painted, place them in areas that receive little or no exposure to the sun and rain, like porch roofs or soffits. Another way to prevent early paint failure is to turn the board so that the bark side is exposed for finishing. The bark side is the side toward which the annual growth rings are convex.

For species that do not provide a good surface for paint, consider applying a non-film-forming penetrating-type finish, such as a water repellent, water-repellent preservative, or a semitransparent penetrating stain instead of paint.

Plywood

Exterior plywood manufactured from southern yellow pine, Douglas-fir, and western redcedar with smooth and roughsawn surfaces is commonly available. Roughsawn plywood with vertical grooving to simulate

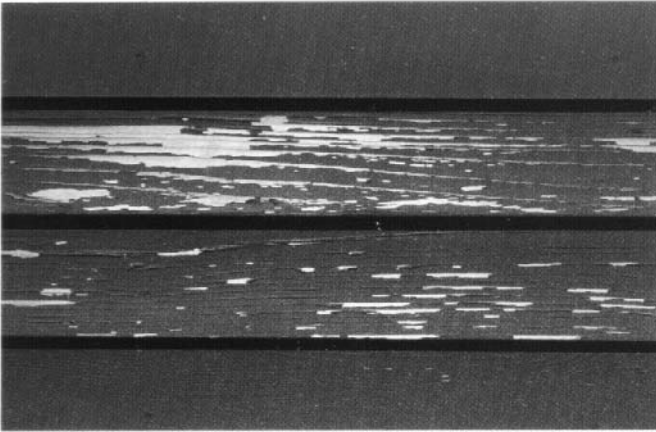

Figure 12—Paint applied to edge-grained boards (top and bottom) performs better than that applied to flat-grained boards (middle).

board-and-batten and other patterns is specified for exterior use (often called texture 1-11 or T 1-11 at the lumberyard). Smooth-sanded plywood is not recommended for siding, but it is often used in soffits. Both smooth and roughsawn plywood will develop surface checks (face checks), especially when exposed to moisture and sunlight. These surface checks can lead to early paint failure with oil or alkyd paint systems (Fig. 13). However, this problem can be avoided by using quality acrylic latex stain-blocking primer and topcoat paint systems. The flat-grained pattern present in nearly all plywood contributes to early paint failure even more than does face checking. Therefore, if smooth or roughsawn plywood is to be painted, special precautions should be exercised. Penetrating stains are often appropriate for smooth-sanded and roughsawn exterior plywood surfaces, but the stains must be renewed regularly.

Plywood should never be left unfinished if it is to be exposed outdoors. The natural weathering process degrades the thin surface veneer of most plywood fairly quickly. Transparent finishes are also unsuitable for plywood because they do not protect the surface from weathering unless they contain ultraviolet radiation stabilizers and water repellents.

Exterior plywood manufactured with a medium-density paper overlay (MDO), in comparison to either smooth or roughsawn plywood, holds paint well. The MDO plywood is not always a stock item in many lumberyards, but it can usually be ordered.

Reconstituted Wood Products

Reconstituted wood products are made by forming small pieces of wood into large sheets, usually 4 by 8 ft, or as required for a specialized use such as beveled dropsiding. These products may be declassified

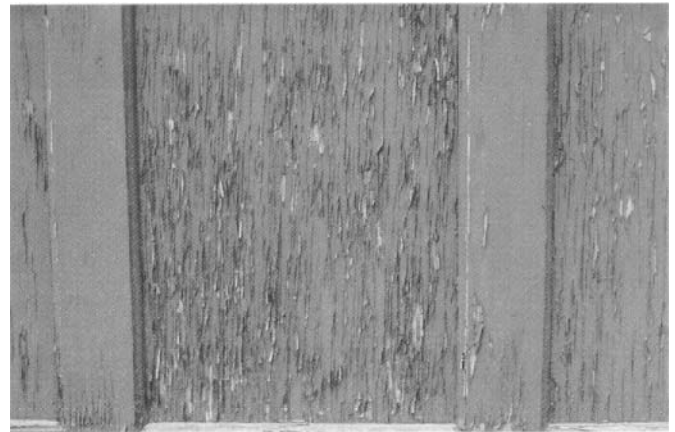

Figure 13—Early paint failure on plywood as a result of penetration of moisture into surface checks.

as either fiberboard or particleboard, depending upon whether the basic component is a wood pulp or wood chips. Along with plywood, these products account for more than half the total surface area of all materials used as exterior siding for newly constructed dwellings and other structures in the United States.

Cardboard is a relatively heavy type of fiberboard. Its tempered or treated form, designed for outdoor exposure, is used extensively as siding. Hardboard is often sold in 4- by 8-ft sheets and as a substitute for beveled drop siding, which has traditionally been made from solid wood.

Particleboard is manufactured from whole wood in the form of splinters, chips, flakes, strands, or shavings. Waferboard and flakeboard are two types of particleboard made from relatively large flakes or shavings. Oriented strandboard (OSB) is a relatively new type of particleboard. To improve the strength properties of this board, the individual particles are aligned to form several layers throughout the board thickness, much like plywood. The surface layers are oriented along the length of the board. In fact, OSB is currently being used in many structural applications previously reserved for plywood.

Only reconstituted wood products manufactured specifically for exterior use should be used. Film-forming finishes such as paints and solid-color stains will give the most protection to these products. Some reconstituted wood products may be factory primed with paint, with or without a topcoat. Others may be overlaid with a resin-treated cellulose fiber sheet (similar to MDO plywood) or with wood veneers. The objective is usually to improve the surface appearance and finishing characteristics. These products are referred to as composites and are often used in specialty applications.

Hardboard can provide an excellent surface for an exterior finish. However, naturally occurring water-soluble wood extractives in hardboard may leach through the paint coat and discolor it. The petrolatum wax used as a water repellent in some hardboard products may cause a discoloration problem known as wax bleed, which can usually be controlled with good painting practices. Research has shown that two- and three-coat systems using acrylic latex stain-blocking primer and topcoat finishes will give good overall performance. Alkyd (oil-based) primers can also be used. However, a water-repellent preservative pretreatment may not be as beneficial for hardboard panel products as it is for solid wood.

Research has also shown that waferboard, OSB, and particleboard may not be suitable (without special precautions) for applications exposed to the weather. Waferboard is prone to delamination of particles as well as to decay when coated with nonporous (oil-based) paint systems, even when pretreated with a water-repellent preservative. However, overlaid products may perform suitably, assuming good construction practices are used.

The edges and ends of all panel products tend to absorb water more readily than the rest of the piece. As a result, they will often swell in thickness. The swelled edges in particleboard, OSB, waferboard, and hardboard will not completely return to their original thickness even when dried out. Therefore, the edges of these products must be treated with a water-repellent preservative and painted to reduce the uptake of moisture.

The choice of siding depends on where the house is built, its price range, and the architectural effect desired. The quality of siding ranges from clear, smooth, edge-grained and rough, knotty, flat-grained lumber and plywood to wood-based panel products made with or without an overlay. Special finishing treatments based on the product are required to achieve the finish life, protection, and esthetic effect desired.

Treated Wood Products

Wood is commonly used in outdoor applications where special treatments with wood preservatives are required for proper protection and best service. Wood in these situations requires protection against decay (rot), insects, and sometimes fire. Typical examples include wood in contact with the soil or exposed to the elements: decks, fences, furniture, wood roofs, and marine structures. Table 5 shows how properly applied wood preservatives can easily extend by tenfold the service life of nondurable woods used in soil contact.

Table 5--Expected service life for southern yellow pine posts in soil contact pressure-treated with different preservatives and exposed in southern Mississippi ^a

Preservative	Estimated service life (years)
Acid copper chromate (ACC)	42
Ammoniacal copper arsenate (ACA)	38
Chromated copper arsenate (CCA)	30 ^b
Chromated zinc chloride (CZC)	38
Coal-tar creosote	38
Pentachlorophenol in oil (PCP) ^c	33
No preservative treatment	3.3

^aForest Products Laboratory field tests.

^bTest still in progress.

^cRestricted-use pesticide.

Commercial pressure processes, when applied according to the industry standards or to the latest Federal specifications, will provide lasting protection, provided the material is installed properly and used as intended by the standards. With nonpressure processes such as brushing, spraying, and even dipping, the preservative normally penetrates the ends of the wood to a small extent and only a thin layer of the outer wood surfaces, and therefore it will not last long in severe applications such as ground or water contact. However, these surface treatments can be useful with wood products used in aboveground low- to medium-decay hazard areas, such as exterior millwork, fencing, and siding.

The three main types of preservatives are (1) preservative oils such as coal-tar creosote, (2) organic solvent solutions such as pentachlorophenol, and (3) waterborne preservatives such as chromated copper arsenate (CCA) and ammoniacal copper arsenate (ACA). Each of these preservative classes has its own unique characteristics and applications.

The preservative oils and the organic solvent solutions in heavy nonvolatile oil leave the wood surface oily and dark. Creosote solutions have a strong odor. These types of preservatives are generally used in commercial applications where severe decay, insect, or marine borer hazards exist and where a long service life is required. Examples include railroad ties, bridge construction, poles, and pilings. Woods treated with these preservatives are not intended for use where human contact is likely.

Wood treated with waterborne preservatives is commonly available at retail lumber yards. It generally has a clean, paintable surface (especially wood treated by a CCA-type pressure treatment), which is characterized by a greenish or brownish color. During the treating process, the wood reacts with the waterborne preservatives to form an insoluble residue. The chromium-containing waterborne preservatives also protect against ultraviolet radiation degradation, an important factor in the weathering process. When purchasing waterborne preservatives, be certain to ask for the consumer information sheet, which outlines the proper use and finishing of the material, and disposal of any residue.

Pressure treatment of wood with preservatives should not be confused with wood treated by vacuum-pressure, dipping, or brushing processes using a water-repellent preservative. Window and door trim are often treated in this way, and the same solution can be brushed onto wood siding. Although these methods do not penetrate the wood deeply, they do provide some protection against decay in aboveground exposure and improve the paint performance.

NOTE: The creosote, pentachlorophenol, and waterborne arsenical wood preservatives are restricted pesticides and can be applied only by licensed pesticide applicators. When purchasing wood products treated with preservatives, be certain to ask for the EPA-approved *Consumer Information Sheet* which outlines proper use, handling, and disposal procedures for this material. (See Appendix B.)

Fire Retardants and Fire-Retardant Coatings for Wood

In addition to treatment with traditional preservatives, wood can be pressure treated with fire-retardant chemicals. The action of fire retardants depends on complicated chemical reactions. In general, the fire-retardant chemical reacts at temperatures below the ignition point of wood to produce noncombustible gases and water vapor. These products dilute the normal flammable gases produced during the initial stages of combustion and thereby slow the combustion process. At the same time, a layer of charcoal is produced on the outside of the wood, thus insulating it against further heating and the release of more flammable gases.

Wood can be treated with several different types of fire retardants. Substantial differences exist between those intended for use indoors and those for exterior applica-

tions. Some retardants used for indoor applications take up moisture readily and thus can prevent good adhesion of a film-forming finish to the surface. Blooming, or the movement of the treating chemical to the surface and subsequent formation of crystals, can also occur. Fire-retardant-treated woods for indoor applications should never be used outdoors.

Generally, different chemicals are used in the treatment of wood intended for exterior applications. These chemicals normally leave a dry water-resistant surface that can be painted following traditional methods. Fire-retardant-treated lumber is normally kiln-dried to

19 percent moisture content after treatment. In the process, the material darkens somewhat, and noticeable marks often result where the lumber contacts the small sticks ("stickers") used to separate the lumber during drying. These sticker marks normally do not weather away with exposure, and application of clear or lightly pigmented stain will not cover them. If a finished appearance showing natural grain and color characteristics is critical, some alternatives do exist. For example, on special orders, the lumber may be surfaced after treatment and drying. A much cleaner, brighter, and smoother surface will result. Some manufacturers use stickers between every other layer of lumber or plywood, so that one surface is left free of sticker marks and can be exposed.

Southern yellow pine and Douglas-fir are two species commonly treated with fire-retardant chemicals. Because these species normally do not hold paint and solid-color stains as well as some other species do, recommended finishing procedures should be strictly adhered to. Western hemlock and ponderosa pine are also treated in this manner and have somewhat better finishing characteristics than southern yellow pine and Douglas-fir.

Because of the variability of wood preservatives and fire retardants available and the different treating processes, the manufacturers or suppliers should be consulted in regard to finishing details. They usually have specific recommendations for achieving maximum service life from paint and other finishes. Wood treated with a preservative or fire retardant should be manufactured in strict adherence to American Wood Preservers' Association (AWPA) standards and should contain a quality stamp indicating the treatment, treating company, and inspection bureau.

Fire-retardant coatings have now been developed and may compete with some pressure-treated materials. However, these materials are awaiting code acceptance before they can be marketed. The coatings will be applied at industrial plants and are not intended for general consumer use.

Weathering of Wood

Natural weathering of wood can be considered the first method of wood finishing in the United States. During the first century of American colonization, exterior surfaces were left to weather naturally. Only later were painted surfaces used by the general populace. Recent interest in colonial traditions and furnishings as well as the do-it-yourself trend has revived the popularity of naturally weathered wood and rustic finishes (Fig. 14). Some wood houses left unfinished to weather naturally have lasted for centuries (Fig. 15).

The esthetic appeal and life expectancy of wood and the compatibility of the wood with potential finishes are greatly affected by the weathering process. This process, which modifies the molecular structure of wood, results from a complex combination of chemical, mechanical, biological, and light-induced changes, all of which occur simultaneously and affect one another. In general, with 2 months of exposure to sunlight, all woods will turn yellowish or brownish, then gray. However, dark woods eventually become lighter and light woods become darker. Subsequently, surface

checks, then cracks may develop. The grain raises and loosens; the boards cup and warp, pulling fasteners loose; and the wood surface becomes friable, with fragments separating from the surface. After the weathered gray surface has developed, usually in a year or two, further changes are very slow to develop.

Steps in Weathering

The first step in the weathering process is the development of a yellowish or brownish color on the surface of light-colored woods (Fig. 16). In redwood, cedar, and hardwoods with dark heartwood, the wood may first develop a bleached appearance before turning brown, but browning can also occur before bleaching. This color change begins on the surface as soon as the wood is exposed to the sunlight and is relatively shallow, ranging from 2/100 to 1/10 in. in depth. The change results from the decomposition of lignin by sunlight, particularly the ultraviolet radiation as well as from organic materials or extractives deposited in the cell lumens of certain wood species. Lignin is the complex chemical structure that holds the individual cells together; it constitutes from 15 to 35 percent of the extractive-free dry weight of wood.



Figure 14—House with western redcedar siding that has been allowed to weather naturally.

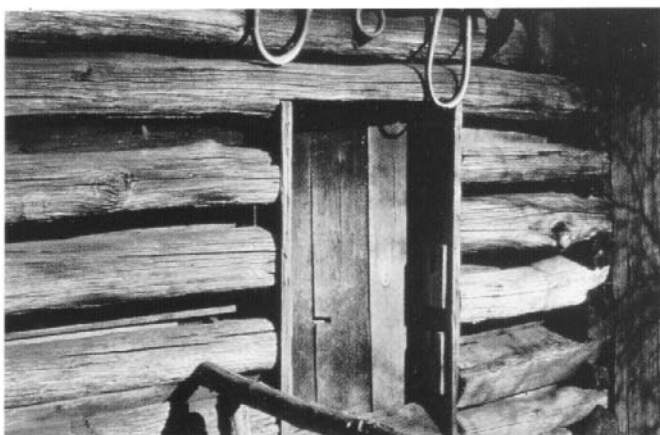

Figure 15--Entrance to old log cabin in Virginia, built in the 1850s. The structure has stood without paint or any other finish for more than 140 years.

As weathering continues, a gray layer, 3/1,000 to 1/100 in. thick, develops. This layer is composed of loosely matted fibers of nearly pure cellulose; rain or moisture leaches out the decomposed brown-colored lignin and extractives. The classic silvery gray color is characteristic of wood exposed to the intense radiation of the sun in cooler climates with little rain or in coastal areas where salt is present in the air.

The gray color of the surface layer of weathered wood usually results from the growth of micro-organisms such as fungi or mildew. Certain species of these organisms occur anywhere a sporadic supply of moisture is available and can produce a uniformly weathered and gray appearance on the wood surface within a year. Unfortunately, micro-organisms may also produce dark spores and mycelia, which can produce the dark gray, blotchy, and unsightly appearance of some weathered wood (Fig. 17). This is a particularly serious problem with unfinished wood in humid areas of the South. All wood surfaces will eventually turn gray when exposed to sun and rain.

Rate of Weathering

Once weathered wood turns gray, additional changes in the wood occur very slowly because the process affects only the surface of the wood. However, the wood surface slowly wears away in a process called erosion. In general, for softwoods like pines, firs, white cedar, redwood, and spruce, about 1/4 in. of wood thickness weathers away every 100 years. The maximum weathering rate reported is 65/100 in. per 100 years for slow-grown (24 annual rings per inch) western redcedar exposed vertically facing south. For dense hardwoods like the oaks, the weathering rate is

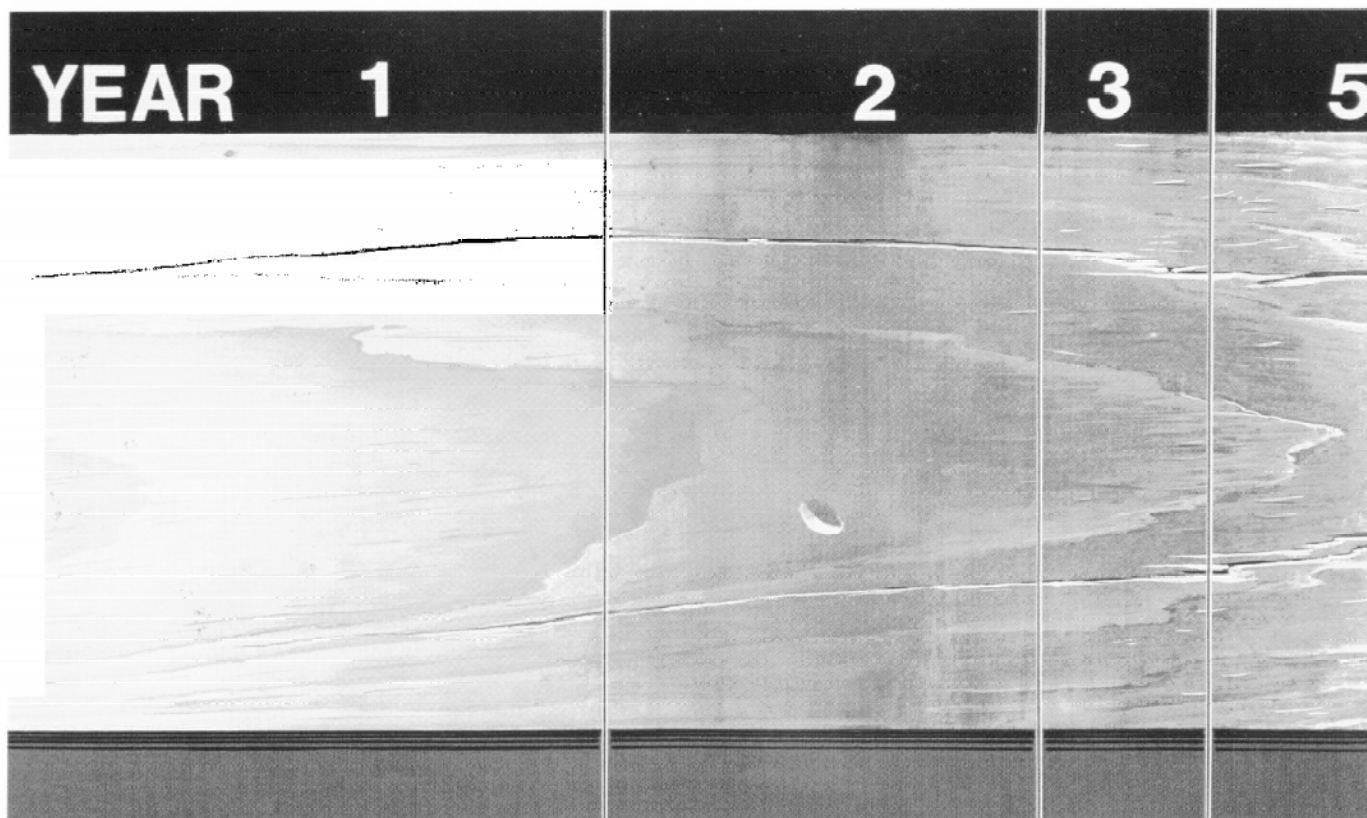

Figure 16--Artist's rendition of color and surface wood changes for a typical softwood during the outdoor weathering process.

only about 13/100 in. per 100 years. The weathering rate is affected by climatic conditions, the amount of exposure, wood density, amount of earlywood and latewood, and ring orientation as well as growth rate and, probably, lignin and extractives content. In general, the less dense the material and the more severe the exposure, the faster the weathering and erosion rate.

Surface Deterioration

In addition to chemical and color changes, mechanical damage occurs on the exposed wood surface, mostly as a result of moisture. Water vapor is adsorbed or released with changes in relative humidity. Rain or dew in contact with the unprotected wood is quickly absorbed by the wood surface. As the moisture content of wood changes, swelling and shrinking occur, resulting in stresses in the surface of the wood. Moisture, in combination with sunlight, causes macroscopic and microscopic intercellular and intracellular cracks and checks. Face-checking as well as warping and cupping can follow, with subsequent nail loosening. Differential swelling and shrinking of earlywood and latewood can also raise the wood grain. Cell wall bonds near the wood surface lose strength: as water continues to erode the softened surface, the surface becomes increasingly uneven and slowly erodes away (Fig.18). Hail and windblown sand or dirt also deteriorate the wood surface.

Although the appearance of weathered wood is attractive for certain architectural effects, it does take time to develop. Moreover, the change caused by weathering seldom occurs evenly over different parts of a building. Those portions exposed to the most sun and rain become weathered first—usually the lower portions of the building, particularly on the south side. The top portions of the building, particularly if protected by large overhangs, porches, or other features, weather more slowly. For a year or two, or even longer unprotected areas, the wood may have a mottled appearance (Fig. 17), varying from that of freshly cut lumbar to gray weathered wood. Dark brown areas from extractives in species such as redwood and western redcedar may persist even longer unprotected areas. The unequal effects of weathering are generally not acceptable, particularly in commercial buildings where the short-term appearance is critical. Where painting is being considered, wood surfaces roughened from weathering obviously provide a very poor substrate for any film-type finish. Even a few weeks of exposure for a new, clean wood surface will decrease its paintability and the life of the paint. On the other hand, somewhat weathered surfaces may be beneficial for penetrating finishes because they allow the wood to absorb more finish solution.

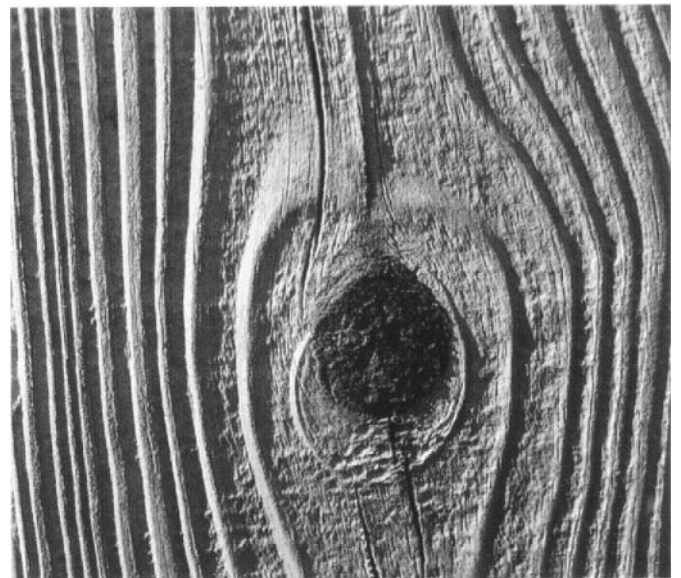
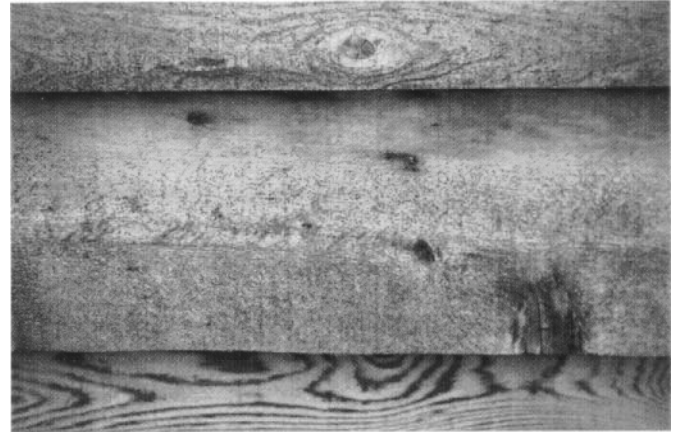

Wood should not be allowed to weather naturally in the South because of the warm, humid climate. Mildew is sure to develop, followed by moss. In some situations, decay may even develop with time.

Wood-Based Materials

The use of plywood, hardboard, and particleboard (including waferboard) for exterior exposure is increasing. The weathering of plywood is directly related to the quality and type of the veneer exposed and to the adhesives used. Small checks are produced in the manufacture of veneer to produce plywood. Exposure to the weather will enlarge these checks, thereby allowing moisture to penetrate deeply into the wood. This is called face checking. Therefore, a water-resistant adhesive must be used for plywood. If

surface checks allow water to enter and become trapped, some decay can be expected in unprotected, nondurable wood species. For these species, a finishing system containing a wood preservative should be used.

Plywood face veneers generally do not exceed 1/4 in. in thickness. Therefore, excessive surface erosion, particularly of light-density species such as western redcedar and redwood, can expose the dark-colored glue line with time. Consequently, plywood should always be protected with a finish that contains a pigment. The more pigment, the greater the protection (paints offer greater protection than do stains). Transparent finishes containing ultraviolet radiation stabilizers and water repellents can also be used, but they are generally less effective at protecting the plywood surface. Such finishes are not recommended for plywood.

Unprotected hardboard and especially particleboard present serious weathering problems. As the outer surfaces are exposed to changes in moisture content, shrinking and swelling of the wood particles, individual fibers, or fiber bundles result. The individual particles or fiber bundles are loosened and separate from the surface. Deeper and deeper layers are subsequently affected at an accelerated rate. As wetting occurs, springback in the wood particles occurs as a result of compression set during the manufacturing process. Significant loss of strength and increased swelling can result after only 1 or 2 years of weathering. Cohesion is lost and panels may fail under mechanical load. For best performance, the surfaces of hardboard and particleboard, including the edges, must be coated with high-quality opaque finishes such as paints or solid-color stains.

Artificial Weathering

There are alternatives to the natural weathering process for solid wood. First, water repellents or water-repellent preservatives may be used to retain the bright color of freshly sawn lumber. This represents a “natural finish” to many consumers. Those finishes containing effective mildewcides work best. Second, penetrating oil-based stains (available in most colors except white) can be applied to protect the wood and provide a uniform color to the structure. Another alternative is to apply a commercially prepared bleaching oil, bleaching stain, or weathering stain. The oil or stain is essentially a water-repellent finish containing some gray pigments. To maintain a uniformly gray wood surface, the bleaching oil may have to be renewed as needed. Or, it may be allowed to wear off naturally, leaving the wood in a more uniform, naturally weathered condition.

In addition to using commercially available products, wood may be treated with several different chemicals or chemical combinations to produce a weathered or aged appearance. Little quantitative information is available concerning these treatments, so some experimentation will be required to obtain an acceptable color.

Artificially stressed and weathered barn boards are also available commercially. The surface texture of artificially weathered wood is produced by rough sawing, sand blasting, wire brushing, and planing with notched knives or other mechanical means. Color is usually controlled by staining or chemical treatment.

Precautions for Weathering Wood

Before wood or wood-based products are left to weather naturally, two factors should be carefully considered. First, wood left to weather naturally will likely develop mildew in warm, humid climates typical in the South. Second, wood that becomes wet, even periodically, can decay. This decay should not be confused with the surface weathering process just described. Wood decay is the biological deterioration of the cellulose and/or lignin throughout the entire thickness of the board. To help guard against decay, which may take from one to several years to develop, all structures should be built so that exposure to both atmospheric and ground moisture is minimized and moisture is not trapped. Furthermore, the naturally durable heartwood of certain species such as the cedars and redwood or preservative-treated wood should be chosen when the chance for decay is high.

Raised grain, checking, and warping are minimal with edge-grained lumber and low-density species as compared to flat-grained wood and high-density species. Warping and cupping can be minimized if the width of the board does not exceed eight times the thickness. Low-density defect-free softwoods tend to warp less than do the lower grades of lumber or high-density species, especially hardwoods.

Moisture-Excluding Effectiveness of Finishes

The various dimensions of wood and wood-based building materials are constantly changing because of changes in moisture content, which in turn are caused by fluctuations in the atmospheric relative humidity as well as the periodic presence of free moisture such as rain or dew. Because film-forming wood finishes like paint will last longer on stable wood, it is sometimes desirable to stabilize wood by treating, finishing, or coating it before painting.

The protection of wood from moisture through applying a finish or coating depends on many variables. Among them are the thickness of the coating film, absence of defects and voids in the film, type of pigment (if any), chemical composition of the vehicle or resin, volume ratio of pigment to vehicle, vapor pressure gradient across the film, and length of exposure period. Regardless of the number of coatings used, the coating can never be entirely moisture proof; there is no way to completely eliminate the changing moisture content of wood in response to changing relative humidities. The coating simply slows down the rate at which the wood changes moisture content.

The effectiveness of several different types of finishes in excluding water vapor from wood has been reported.³ The numeric rating given for each finish type is a relative value based on a three-coat system applied on wood at 80°F and 30 percent relative humidity, then exposed for 14 days at the same temperature and 90 percent relative humidity. Perfect protection, or no adsorption of water vapor, is represented by 100 percent effectiveness; complete lack of protection (as with unfinished wood) by 0 percent. In this study, the most effective coating was molten paraffin wax applied by dipping (one coat), with a rating of 95 percent for moisture vapor excluding effectiveness after 14 days. However, this is not a practical finish, and it can accumulate dirt and mildew. This finish was included to demonstrate the difficulty of excluding moisture, especially in the vapor form, from wood. Commercially available finishes and their three-coat effectiveness ratings after 14 days at 90 percent relative humidity are as follows:

Finish	Effectiveness rating (percent)
Epoxy finish-clear	91
Epoxy paint-gloss	87
Aluminum flake-pigmented urethane varnish (oil-modified)	84
Aluminum paint (linseed-phenolic-menhaden)	82
Enamel paint—satin (soya-tung)	80

On the other hand, porous paints, such as latex paints and low-luster (flat) or breather-type oil-based paints formulated at a pigment volume concentration usually above 40 percent, afford little protection against moisture. These paints permit rapid entry of water from

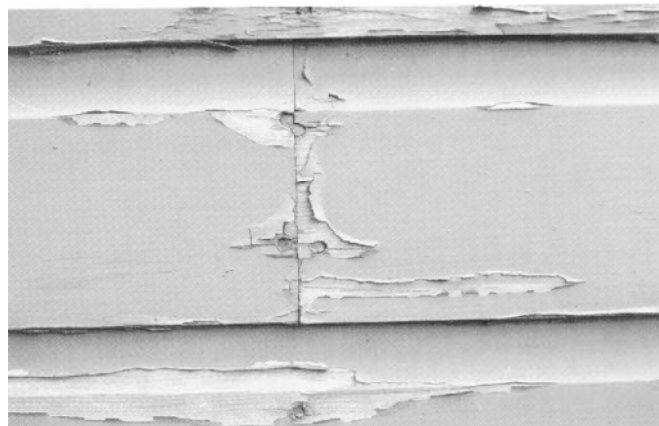

Figure 19—Paint normally fails initially around the ends and edges of a board. Liberal application of a water repellent or water-repellent preservative, especially to the end grain, can prolong paint life in these areas.

dew and rain unless applied over a nonporous primer. Likewise, penetrating finishes like linseed oil, tung oil, water repellents, and stain-type finishes, are ineffective against water vapor.

Good exterior coatings either retain their maximum moisture-excluding effectiveness for a considerable time or lose effectiveness slowly. As long as the original appearance and integrity of the coating are retained, most of the effectiveness remains. Paint that is faded or chalked remains effective if vigorous rubbing removes the chalk and reveals a glossy film. Deep chalking, checking, or cracking indicates serious impairment of the moisture-excluding effectiveness of the finish.

The degree of protection provided by different treatments depends on the type of exposure. For example, water-repellent treatments may be ineffective against a long-term exposure (2 weeks) to water vapor, but relatively effective against free water for a short (1/2-h) exposure time.

For a coating to be effective in minimizing moisture content changes of the wood, it must be applied to all wood surfaces, particularly the end grain. The end grain of wood absorbs moisture much faster than does the face grain, and finishes generally fail in this area first (Fig. 19). Coatings applied to one surface only will result in unequal sorption of moisture, increasing the likelihood of wood cupping. A buildup of the finish (two and preferably three coats) is also required because mere plugging of the wood pores is not effective. The cell walls at the surface must likewise be fully covered.

³Feist, William C., James K. Little, and Jill M. Wennesheimer. *The moisture excluding effectiveness of finishes on wood surfaces*. Res. Pap. FPL 462. Madison, WI: US. Department of Agriculture, Forest Service, Forest Products Laboratory; 1985. 38 p.

The first or primer coat applied to bare wood is rarely effective. In those houses where moisture is moving from the living quarters to the outside wall because there is no vapor retarder, the application of moisture-excluding finishes to the outside will not prevent paint peeling.

Types of Exterior Wood Finishes

Finishes or coatings are applied to exterior wood surfaces for a variety of reasons. The particular reason will determine the type of finish selected and subsequently the amount of protection provided to the wood surface as well as the life expectancy for the finish. Finishes can be divided into two general categories: (1) opaque coatings, such as paints and solid-color stains, and (2) natural finishes, such as water repellents, water-repellent preservatives, oils, and semitransparent penetrating stains. Wood preservatives and fire-retardant coatings might also be called “finishes” in some respects. Various types of wood preservatives and finishes for exterior wood are summarized in Table 6; suitability of finishing methods and expected service life are summarized in Table 7.

Opaque Finishes

Paint

Paints are common coatings used on wood that provide the most protection against surface erosion by weathering and against wetting by water (Fig. 20). They are also used for esthetic purposes and to conceal certain defects. Paints contain substantial quantities of pigments, which account for the wide range of colors available. Some pigments will essentially eliminate ultraviolet radiation degradation of the wood surface. Oil-based or alkyd-based paints are a suspension of inorganic pigments in a resin vehicle and a petroleum or turpentine solvent that helps carry the pigment particles and the bonding agent (resin) to the wood surface. Latex paints are likewise a suspension of inorganic pigments and various latex resins, but the solvent or dispersant in this case is water.

Oil-based paint films usually provide the best shield from liquid water and water vapor. However, they are not necessarily the most durable because they become brittle over time. No matter how well sealed, wood still moves with seasonal humidity, thus stressing and eventually cracking the brittle paint. On the other hand, latex paints, particularly all-acrylic paint, remain more flexible with age. Even though latex paints allow more water vapor to pass through, they hold up better by

stretching and shrinking with the wood. Test fences at the Forest Products Laboratory and other laboratories show that all-acrylic latex topcoat paints applied in two coats over a stain-blocking acrylic latex primer last longer than other paint systems even on difficult-to-paint roughsawn plywood surfaces.

Latex paints are generally easier to use than oil-based paints because water is used for cleanup. They are also porous and will allow some moisture movement. In comparison, oil-based paints require organic solvents for cleanup, and at least some are nonporous. A nonporous paint film retards penetration of outside moisture and reduces the problem of discoloration by wood extractives, peeling of paint from outside moisture sources, and checking and warping of the wood. **However, paint is not a preservative. It will not prevent decay if conditions are favorable for fungal growth.**

Paints perform best on smooth, edge-grained lumber of light-density species such as redwood and cedar and are the only way to achieve a bright, white finish. Paints are applied to the wood surface and do not penetrate the wood deeply. Rather, the wood grain is completely obscured and a surface film is formed. This film can blister or peel if the wood is wetted or if inside water vapor moves through the house wall and wood siding because of the absence of a vapor barrier. Original and maintenance costs are often higher for a paint finish than for a water-repellent preservative or penetrating stain finish (Table 6).

Most complaints about paint involve low-cost products, indicating that quality paints are usually worth the extra money. Better quality paints usually contain 50 percent solids by weight. Paints with a lower percentage of solids may cost less by the gallon but be more expensive per pound of solids, and more or heavier coats will have to be applied to achieve equal coverage. The Forest Products Laboratory evaluates paints by generic type only. Consumer Reports (256 Washington St., Mount Vernon, NY 10550) describes the results of extensive weather testing by paint brand as do other publications.

Solid-Color Stains

Solid-color stains (also called hiding, heavy-bodied, or opaque stains) are opaque finishes that come in a wide range of colors and are essentially thin paints. Solid-color stains are made with a much higher concentration of pigment than are the semitransparent penetrating stains, but a somewhat lower concentration of pigment than that of standard paints. As a result, solid-color stains obscure the natural wood color and grain, and

Table 6--Initial application and maintenance of exterior wood finishes ^a

Finish	Initial application		Appearance of wood	Maintenance		
	Process	cost		Process	cost	Timing
Waterborne preservative	Brushing	Low	Grain visible; wood brown to black, fades slightly with age	Brush to remove surface dirt	Low	3-5 years
	Pressure	Medium	Grain visible; wood greenish or brownish, fades with age	Brush to remove surface dirt	Nil, unless stained, painted, or varnished	Nil, unless stained, painted, or varnished
	Diffusion plus paint	Low to medium	Grain and natural color obscured	Clean and repaint	Medium	7-10 years
Organic solvent preservative ^b	Pressure, steeping, dipping, and brushing	Low to medium	Grain visible; color as desired	Brush down and reapply	Medium	2-3 years or when preferred
Water repellent and oils ^c	One or two brush coats of clear material or, preferably, dip application	Low	Grain and natural color visible, becoming darker and rougher textured with age	Clean and reapply	Low to medium	1-3 years or when preferred
Semitransparent stain	One or two brush coats	Low to medium	Grain visible; color as desired	Clean and reapply	Low to medium	3-6 years or when preferred
Clear varnish	Three coats (minimum)	High	Grain and natural color unchanged if adequately maintained	Clean and stain bleached areas; apply two more coats	High	2 years or when breakdown begins
Paint and solid-color stain	Brushing: water repellent, prime, and two topcoats	Medium to high	Grain and natural color obscured	Clean and apply topcoat, or remove and repeat initial treatment if damaged	Medium	7-10 years for paint; ^d 3-7 years for solid-color stain

^aThis table is a compilation of data from the observations of many researchers.

^bPentachlorophenol, bis(tri-n-butyltin oxide), copper naphthenate, copper-8-quinolinolate, and similar materials.

^cWith or without added preservatives. Addition of preservative helps control mildew growth.

^dIf top-quality acrylic latex topcoats are used.

Table 7--Suitability and expected service life of finishes for exterior wood surfaces ^a

Type of exterior wood surface	Water-repellent preservative and oil		Semitransparent stain		Paint and solid-color stain		
	Suitability	Expected life ^b (years)	Suitability	Expected life ^c (years)	Suitability	Expected life (years) ^d	
						Paint	Solid-color stain
Siding							
Cedar and redwood							
Smooth (vertical grain)	High	1-2	Moderate	2-4	High	4-6	3-5
Roughsawn	High	2-3	High	5-8	Moderate	5-7	4-6
Pine, fir, spruce							
Smooth (flat-grained)	High	1-2	Low	2-3	Moderate	3-5	3-4
Rough (flat-grained)	High	2-3	High	4-7	Moderate	4-6	4-5
Shingles							
Sawn	High	2-3	High	4-8	Moderate	3-5	3-4
Split	High	1-2	High	4-8	..	3-5	3-4
Plywood (Douglas Fir and Southern Pine)							
Sanded	Low	1-2	Moderate	2-4	Moderate	2-4	2-3
Textured (smooth)	Low	1-2	Moderate	2-4	Moderate	3-4	2-3
Textured (roughsawn)	Low	2-3	High	4-8	Moderate	4-6	3-5
Medium-density overlay ^e	--	--	--	--	Excellent	6-8	5-7
Plywood (cedar and redwood)							
Textured (smooth)	Low	1-2	Moderate	2-4	Moderate	2-4	2-3
Textured (roughsawn)	Low	2-3	High	5-8	Moderate	4-6	3-5
Hardboard, medium density^f							
Smooth							
Unfinished	..	--	--	--	High	4-6	3-5
Preprimed	..	--	..	--	High	4-6	3-5
Textured							
Unfinished	--	..	--	..	High	4-6	3-5
Preprimed	--	..	--	..	High	4-6	3-5
Millwork (usually pine)							
Windows, shutters, doors, exterior trim	High ^g	..	Moderate	2-3	High	3-6	3-4
Decking							
New (smooth)	High	1-2	Moderate	2-3	Low	2-3	1-2
Weathered (rough)	High	2-3	High	3-6	Low	2-3	1-2
Glued-laminated members							
Smooth	High	1-2	Moderate	3-4	Moderate	3-4	2-3
Rough	High	2-3	High	6-8	Moderate	3-5	3-4
Oriented strandboard	Low	1-3	Moderate	2-4	2-3

^aThese data were compiled from the observations of many researchers. Expected life predictions are for an average location in the continental United States; expected life will vary in extreme climates or exposure (such as desert, seashore, and deep woods).

^bDevelopment of mildew on surface indicates need for refinishing.

^cSmooth unweathered surfaces are generally finished with only one coat of stain. Roughsawn or weathered surfaces, which are more adsorptive, can be finished with two coats; the second coat is applied while the first coat is still wet.

^dExpected life of two coats, one primer and one topcoat. Applying a second topcoat (three-coat job) will approximately double the life. Top-quality acrylic latex paints will have the best durability.

^eMedium-density overlay is generally painted.

^f*Semitransparent stains are not suitable for hardboard. Solid-color stains (acrylic latex) will perform like paints. Paints are preferred.*

^gExterior millwork, such as windows, should be factory treated according to Industry Standard 1S4-81. Other trim should be liberally treated by brushing before painting.



Figure 20---Two southern houses maintained with good painting practices. (Photos courtesy of Southern Forest Products Association.)

they can also be applied over old paints or solid-color stains. However, surface texture is retained and a flat-finish appearance normally results. Like paints, solid-color stains protect wood against ultraviolet radiation degradation. Oil-based solid-color stains form a thin film much like paint and consequently can also peel loose from the substrate. Film-forming, latex-based solid-color stains are also available. The acrylic-based versions are generally the best of all the solid-color stains. Solid-color stains are often used on textured surfaces and panel products such as hardboard and plywood. These stains are most effective when applied in two or three coats. At least two coats are essential on all panel products, and three coats are preferable.

Natural Finishes

In many locations throughout the United States, there is a continuing trend toward the use of natural colors and finishes to protect exterior wood siding and trim. Architects, builders, and owners are increasingly specifying a “natural look” for homes, apartments, churches, and commercial buildings. To some, a natural look means rough, gray, and weathered. This is nature’s “natural finish” (Figs. 14, 15). To others, a truly successful natural exterior wood finish is one that will retain the original, attractive appearance of the wood with the least change in color and the least masking of wood grain and surface texture. In this case, the finish should inhibit the growth of mildew micro-organisms, protect against moisture and sunlight, and not change the surface appearance or color of the wood.

The most natural appearance for wood is achieved without a protective finish. Unfortunately, in the normal weathering process, the appearance of unprotected wood exposed outdoors is soon changed by the adverse effects of light, moisture, and the growth of micro-organisms on the surface. The original surface becomes rough as the grain raises and the wood checks, and the checks sometimes grow into large cracks. The grain may loosen, and boards may cup, warp, and pull away from fasteners. Roughened surfaces change color rapidly, gather dirt, and often mildew, and they may become unsightly; the wood loses its surface coherence and becomes friable. Where salt in the atmosphere inhibits excessive mildew growth, natural weathering may create a changed but desirable silver-gray appearance in the exposed wood. In dry or cold climates, a rustic, brown-to-gray patina may result. In many humid locations, however, weathering is often accompanied by a surface growth of dark gray, black, or blotchy mildew that may remain uneven and unsightly until the wood has weathered for many years. In these climates, application of a “natural” finish is often desirable.

The natural finishes can be divided into two categories: (1) the penetrating types, such as transparent water repellents, water-repellent preservatives, oils, and semitransparent and pigmented oil-based stains, and (2) the film-forming types, such as varnishes. Shellacs and lacquers, which are film-forming finishes, are not recommended for exterior use because they are easily damaged by moisture.

Water-Repellent Preservatives

A water-repellent preservative may be used as a natural finish (Fig. 21). The treatment reduces warping and checking, prevents water staining at the edges and ends of wood siding, and helps control mildew growth. Water-repellent preservatives contain a fungicide, a small amount of wax as a water repellent, a resin or drying oil, and a solvent such as turpentine, mineral spirits, or paraffinic oil. Some contain ultraviolet radiation stabilizers. The wax reduces the absorption of liquid water by the wood (Fig. 22), and the preservative prevents wood from darkening (graying) by inhibiting the growth of mildew and decay organisms. Some waterborne formulations are also available. Water-repellent preservatives without special additives will not protect the wood surface from ultraviolet radiation damage unless ultraviolet radiation stabilizers are added to the finish. Ultraviolet radiation from the sun slowly degrades the surface of wood, releasing fibers and groups of fibers. The resulting finish will vary in color, depending upon the wood color itself, but will usually weather to a clean, golden tan.

The initial application of a water-repellent preservative to smooth surfaces is *short* lived, usually lasting 1 to 2 years on smooth surfaces and 1 to 3 years on roughsawn or weathered surfaces. When a surface starts to show a blotchy discoloration resulting from extractives or mildew, it should be cleaned with a solution of liquid household bleach and detergent and re-treated after drying (see section on prevention and removal of mildew). During the first few years, a fresh finish may have to be applied every year or so. After the wood has gradually weathered to a uniform tan color, additional treatments may last 2 to 4 years because the weathered boards absorb more finish.

Water-repellent preservatives do not contain any coloring pigments but will darken the color of the wood. Relatively small quantities of tinting colors can be added to the water-repellent preservative solution to provide special color effects; the mixture is then classified as a pigmented penetrating preservative stain. Two to six fluid ounces of tinting colors or color in oil per gallon of treating solution are normally used. Colors that match the natural color of the wood and extractives are preferred. As with semitransparent

penetrating stains, the addition of pigment to the finish helps stabilize the color and increase the durability of the finish because ultraviolet radiation is partially blocked.

Paintable water-repellent preservatives may also be used as a treatment for bare wood before priming and painting or in areas where old paint has peeled, exposing bare wood, particularly around butt joints or in corners. This treatment keeps rain or dew from penetrating the wood, especially at joints and on end grain, thus decreasing the shrinking and swelling of the wood. As a result, less stress is placed on the paint film, and its service life is extended (Figs. 19 and 23). This stability is achieved by the small amount of wax or other water repellent present in the water-repellent preservative. Providing the entire board has been treated, the wax also decreases the capillary movement of water up the back side of lap or drop siding. The fungicide inhibits surface decay mold and mildew. For treating bare wood, make certain that the manufacturer's label indicates that the water-repellent preservative is paintable. Some products have too much wax or other water repellents and the paint will not adhere adequately.

Water repellents are also available. These are simply water-repellent treatments without preservative. However, solutions with preservatives will provide better protection in the South because of the severity of moisture, decay, and mildew problems.

The composition of typical water repellents and water-repellent preservatives is given in Table 8.

Care should be exercised when purchasing water repellents or water-repellent preservatives. Manufacturers' specifications should be read carefully and followed completely. Any type of water-repellent preservative can be used as a natural exterior finish by itself, but only *some* are paintable. Manufacturers have also developed water-repellent preservatives specifically for exterior natural finishes. In areas where decay is a serious problem or where wood will be in contact with the ground or water, wood that has been pressure treated with an appropriate preservative should be purchased.

CAUTION: Water repellents and water-repellent preservatives should always be mixed, handled,



Figure 21—Modern house with a natural water-repellent preservative finish. (Photo courtesy of Southern Forest Products Association.)

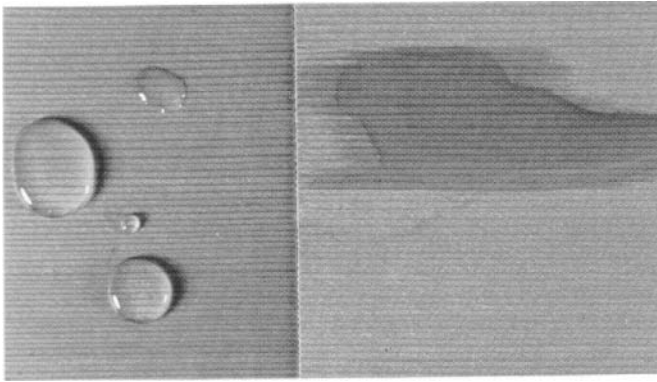

Figure 22— Wood surface brush-treated with water repellent (left). The treated surface resisted penetration by liquid water, whereas the untreated wood surface (right) absorbed water quickly.

and applied carefully. The safest place for mixing is outdoors. Solutions with solvents are volatile and flammable. Their vapors should not be inhaled or exposed to flame or sparks. Wear protective clothing on hands and arms and take care not to splash the solution into eyes or onto the face. Remember that water-repellent preservatives may contain toxic materials. Read any labels carefully.

Oils

Many oil or oil-based natural wood finish formulations are available for finishing exterior wood. The most common oils are linseed and tung. However, these oils may serve as a food source for mildew if applied to wood in the absence of a mildewcide. The oils will also perform better if a water repellent is included in the formulation. Alkyd resin and related resin commercial formulas are also available. All these oil systems will protect wood, but their average lifetime may be only as long as that described for the water-repellent preservatives.

Semitransparent Penetrating Stains

The Forest Products Laboratory Natural Finish was one of the first semitransparent penetrating stains formulated. It is the basis of some commercial formulations and presents the option of preparing a finish from basic ingredients.⁴

Since the development of the Forest Products Laboratory Natural Finish, semitransparent penetrating stains have grown in popularity and are available in nearly all paint supply stores. These stains are moderately

⁴Mack, John M., Don F. Laughnan, and Edward A. Mraz. Forest Products Laboratory Natural finish. Research Note FPL-046. Madison, WI: U.S. Department of Agriculture, Forest Service, Forest Products Laboratory. Rev. 1975. 6p.

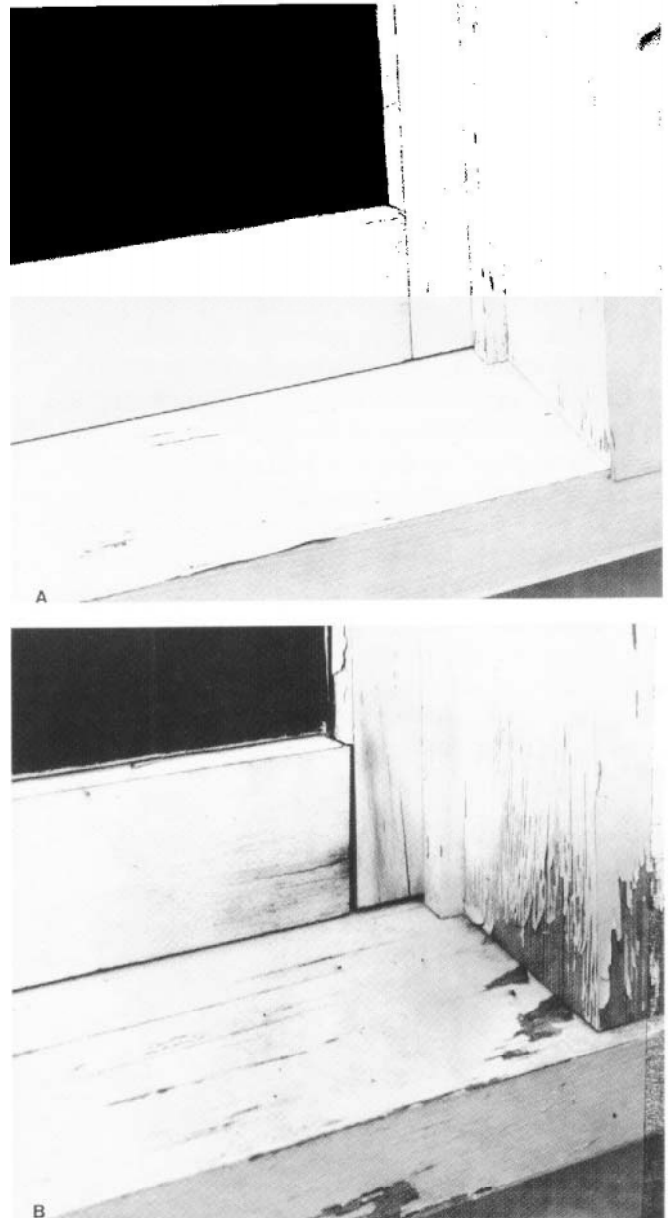

Figure 23---Treatment of wood with water-repellent preservative. (A) window sash and frame treated and then painted; (B) window sash and frame not treated before painting. In both cases, wood was weathered for 5 years. Note the normally weathered paint and good condition of the wood and glazing on the treated structure. (M 119 770, M 119 771)

pigmented water repellents or water-repellent preservatives. They penetrate the wood surface to a degree, are porous, and do not form a surface film like paint. Thus, they do not totally hide the wood grain and will not trap moisture that may encourage decay (Fig. 24). As a result, the stains will not blister or peel even if moisture penetrates the wood. Design and construction practices are not as critical for the long life of a semitransparent penetrating stain compared to that of a film-forming finish.

Table 8--Composition of typical water repellents and water-repellent preservatives

Ingredient	Approximate composition (percent by weight)	
	Water repellent	Water-repellent preservative
Preservative ^a	0	0.25-5
Resin or drying oil ^b	10	10
Paraffin wax	0.5-1	0.5-1
Solvent (turpentine, mineral spirits, or paint thinner)	89	84-89

^a Examples of preservatives used commercially and their typical concentrations (by weight) include copper-naphthenate, 2 percent as copper metal; zinc naphthenate, 2 percent as zinc metal; bis(tri-N-butyltin) oxide, 0.15 to 0.675 percent; copper-8-quinolinolate, 0.15 to 0.675 percent; 3-iodo-2-propynyl butyl carbamate, 0.5 percent; N-(trichloromethylthio) phthalimide, 0.5 percent; and 0.5 percent 2-(thiocyanomethylthio) benzo thiazole (TCMTB).

^b Typical examples are boiled linseed oil, tung oil, exterior grade varnish resins, and alkyd resins.

Penetrating stains are oil based (or alkyd based), and some may contain a fungicide (preservative or mildewcide), ultraviolet light stabilizer, or water repellent. Make certain that the manufacturer's label indicates that the finish will resist mildew or that the product contains a specific mildewcide. All fungicides are not effective against mildew. Latex-based (waterborne) stains are also available, but they do not penetrate the wood surface as do their oil-based counterparts. Newer latex formulations are being developed that may provide some penetrating characteristics.

The type and amount of pigments determine the appearance or hue of the stain. The pigment particles help to protect the wood surface from the degrading effects of ultraviolet radiation from the sun. High-quality iron oxide pigments are very durable, and other pigments may prove only slightly less so. Durability, however, depends largely on the amount of pigment or stain applied to the surface. Doubling the amount of pigment in the formula will therefore improve durability but will make the finish less transparent and the color more intense.

Semitransparent penetrating stains are most effective on rough lumber or plywood surfaces because more finish can be applied. They also provide satisfactory

performance on smooth wood surfaces but not smooth plywood surfaces. These stains are also an excellent finish for weathered wood and flat-grained surfaces of dense species, such as southern yellow pine, that do not hold paint well. Available from commercial sources in a variety of colors, semitransparent penetrating stains are especially popular in brown or red earth tones, which provide a "natural" or "rustic" appearance to the wood. These stains are not usually available in white. Semitransparent penetrating stains are not effective when applied over a solid-color stain or old paint coat.

NOTE: Semitransparent stains are not recommended for hardboard, waferboard, oriented strandboard, and similar panel surfaces.

The first application of a semitransparent penetrating stain to a smoothly planed surface fully exposed to the weather generally lasts about 2 to 3 years (Table 6). When refinished after weathering, the finish will usually last much longer. Two coats of stain applied to roughsawn or weathered surfaces may last 6 to 8 years or more. In general, oil- or alkyd-based semitransparent stains provide at least twice and often three times the service life of the unpigmented water-repellent preservatives or other transparent finishes.

In finishing the wood of high-density species such as southern yellow pine and Douglas-fir, the surface may be treated with a water-repellent preservative and allowed to weather for a year before staining. The first coat of stain will then penetrate uniformly and be more durable because weathering has made the wood surface more absorptive.

Semitransparent penetrating stains have also been used successfully over other penetrating natural finishes (oils, water-repellent preservatives) that have weathered. If the finish penetrates well into the previously finished surface, it will appear flat. If the finish does not penetrate, it will dry slowly with numerous glossy areas and probably will not be as durable as it is on new wood. Old varnish, paint, and solid-color stain films must be completely removed before applying a penetrating stain.

Transparent Film-Forming Coatings

Clear coatings of conventional spar, urethane, or marine varnish, which are film-forming finishes, are not generally recommended for exterior use on wood. Ultraviolet radiation from the sun penetrates the transparent film and degrades the wood under it. Regardless of the number of coats applied, the finish will eventually become brittle as a result of exposure to sunlight, develop severe cracks, and peel, often in less



Figure 24—Modern houses finished with semitransparent penetrating oil-based stains. (Photos courtesy of Southern Forest Products Association.)

than 2 years (Fig. 25). Photochemically degraded fibers peel from the wood along with the finish. If the finish does not require a long service life, areas that are protected from direct sunlight by an overhang or porch and are on the north side of a structure can be finished with exterior-grade varnish. In these areas, a minimum of three coats of finish is recommended, and the wood should be treated initially with a paintable water-repellent preservative. The use of varnish-compatible pigmented stains and sealers as undercoats will also contribute to a longer life for the clear finish. In marine exposures, six coats of varnish should be applied for best performance.

A finish that nearly forms a film has recently been developed in Europe. This finish is commonly called a varnish stain. The film of varnish stain is thicker than that provided by a semitransparent stain, but thinner than that provided by a varnish. Varnish stains contain a water repellent, special transparent iron oxide pigments, and mildewcides. The surface coating will slowly erode and can be refinished easier than that provided by a conventional varnish. Varnish stains are usually applied initially as three-coat systems.

There are two other types of film-forming transparent coatings, but neither works well in exterior applications. Two-part polyurethane are tougher and perhaps more ultraviolet radiation resistant than other transparent film-forming coatings, but they are expensive, difficult to use, and usually have as short a life as conventional varnishes. The second type, lacquers and shellac, is not suitable for exterior application, even as sealers or primers, because these coatings have little resistance to moisture. These finishes are also normally brittle and thus crack and check easily. However, specialty pigmented knot sealer primers based on shellac are available for specific exterior applications.

Fire-Retardant Coatings

Most conventional decorative coatings in themselves will slightly reduce the flammability of wood products when applied in conventional film thicknesses. However, for improved protection, commercial fire-retardant, paint-like coatings have been developed. These products provide varying degrees of protection. Fire-retardant coatings generally have low surface flammability characteristics. The coatings form an expanded low-density film upon exposure to fire (intumesce), thus insulating the wood surface below from heat and retarding burning. Additional ingredients restrict the flaming of any released combustible vapors. Chemicals may also be present in these coatings that promote decomposition of the wood surface to charcoal and water rather than to the formation of volatile flammable products.

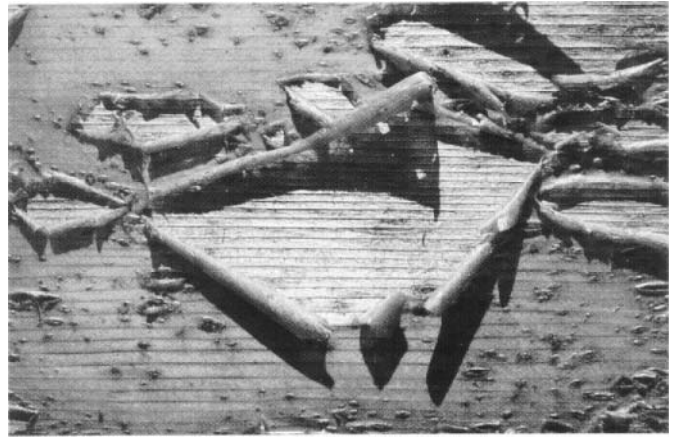

Most fire-retardant coatings are intended for interior use. Conventional paints can be applied over the coatings to improve the durability of the fire retardant.

Application of Exterior Wood Finishes

The correct application of a finish or coating to a wood surface is as important for durability and good performance as selecting the most appropriate finish. All finishes are either brushed, rolled, sprayed, or applied by dipping. The application technique used, the quantity and quality of finish applied, the surface condition of the substrate, and the weather conditions existing at the time of application can substantially affect the life expectancy of the finish. In the following section, we discuss different methods of finish application along with other important variables. For optimum performance, manufacturers' directions should always be read and followed.

Opaque Finishes

Paint

Proper surface preparation is absolutely essential for the good performance of paint. Wood and wood-based products should be fully protected from the weather and wetting during and after installation or installation. Surface contamination from dirt, oil, and other foreign substances must be eliminated. All paints and primers used in humid climates should contain a mildewcide. Preliminary research has shown that even a 3- to 4-week exposure of a freshly cut wood surface to the weather (especially the sun) can adversely affect the adhesion of paint to the wood. Wood surfaces should be painted as soon as possible, weather permitting,

before or after installation. Wood that has weathered badly before painting will have a degraded surface that is not good for painting, and a paint coating is more likely to peel from the more degraded areas. The weathered wood should be sanded and washed before painting.

To achieve maximum paint life, follow these steps:

1. Treat properly cleaned wood siding and trim with a paintable water-repellent preservative or water repellent and caulk all joints and cracks. Water repellents protect the wood against the entrance of rain and dew and thus prevent swelling and shrinking. This is especially true for species like southern yellow pine. Water repellents can be applied by brushing or dipping. Lap and butt joints and the edges of panel products such as plywood, hardboard, and particle board should be especially well treated since paint normally fails in these areas first (Fig. 19). Allow at least 2 warm, sunny days for adequate drying before painting the treated surface. If enough time is not allowed for the solvent to evaporate, the paint applied over the treated wood may be slow to dry, may discolor, or may dry with a rough surface that resembles alligator hide. If the wood has been dip treated, allow it to dry for at least 1 week, if the weather is favorable. The small amount of wax (less than 1 percent) in a paintable water-repellent preservative will not prevent proper adhesion of the paint.
2. After the water-repellent preservative or water repellent has dried, prime the bare wood as soon as possible. The primer coat is very important because it forms a base for all succeeding paint coats. For woods with water-soluble extractives, such as red wood and cedar, the best primers are good-quality oil-based, alkyd-based, or stain-blocking acrylic latex-based primer paints. The primer seals in or ties up the extractives so that they will not bleed through the topcoat. The primer should also be nonporous and thus inhibit the penetration of rain or dew into the wood surfaces, reducing the tendency of the wood to shrink and swell. A primer should be used whether the topcoat is an oil-based or latex-based paint. For species, such as pine, that are predominately sap wood and free of extractives, a high-quality acrylic latex paint may be used as both a primer and topcoat. Enough primer should be applied to obscure the wood grain, but the primer should not be spread too thin, and the application rates recommended by the manufacturer should be followed. A primer coat that is uniform, flexible, and of the proper thickness will distribute the swelling stresses that develop in wood and thus prevent premature paint failure. The topcoat should be applied as soon as the primer coat is dry—about 48 hours for oil-based paints—or as recommended by the manufacturer. Special knot primers are available.
3. Apply two coats of a good-quality all-acrylic latex house paint over the primer. If it is not practical to apply two topcoats to the entire house, two topcoats must be applied to fully exposed areas on the south and west sides of the house to obtain good protection. Areas fully exposed to sun and rain are the first to deteriorate. Vinyl-acrylic, modified-acrylic, and oil-based topcoat paints can also be used. Allow the first coat of oil-based paint to cure for 1 to 2 days before applying the second coat. In cold or damp weather, an extra day or two should be allowed between coat applications. Coats of latex paint can usually be applied within a few hours of each other. On those wood surfaces best suited for painting, one coat of a good house paint (acrylic latex) over a properly applied primer (a conventional two-coat paint system) should last 4 to 5 years, but two topcoats over one primer coat can last up to 10 years (Table 7).
4. Apply 1 gal of paint per approximately 400 ft² of smooth wood surface area. However, coverage can vary with different paints, surface characteristics, and application procedures. Research has indicated that the optimum thickness for the total dry paint coat (primer and two topcoats) is 3.5 to 5 mils or about the thickness of a sheet of newspaper. Some paints (especially latex) will successfully cover the primer coat at one-half this thickness, but these thin coats will erode rapidly. On the other hand, thick paint coats tend to build up and develop cracks. The coverage of a paint coat can be checked by applying a pint of paint evenly over a measured area that corresponds to that recommended by the manufacturer. Brush application is usually superior to roller, spray, or painting-pad application, especially for the first coat. Professional painters can usually spray paint and obtain good performance. The quality of paint is usually, but not always, related to the price.

To avoid future separation between paint coats, the first topcoat should be applied within 2 weeks of the primer and the second coat within 2 weeks of the first. As certain primer paints weather, they can form a soap-like substance on their surface that may prevent proper adhesion of new paint coats. If more than 2 weeks elapse before applying another paint coat, scrub the old surface with water using a bristle brush or sponge. If necessary, use a mild detergent to remove all dirt and deteriorated paint, or, if mildew develops, clean the surface with bleach. Then, rinse the surface with water and allow it to dry before painting. Repriming may be necessary if the old primer has weathered more than 2 weeks.

To avoid temperature blistering, oil-based paints should not be applied on a cool surface that will be heated by the sun within a few hours. Temperature blistering is

most common with thick paint coats of dark colors applied in cool weather. The blisters usually appear in the last coat of paint and occur within a few hours to 1 or 2 days after painting. They do not contain water.

Oil-based paint may be applied when the temperature is 40°F or above. A minimum of 50°F is desirable for applying latex-based paints. For proper curing of latex paint films, the temperature should not drop below 50°F for at least 24 hours after paint application. Low temperatures will result in poor coalescence of the paint film and early paint failure.

Wrinkling, fading, or loss of gloss in oil-based paints and streaking of latex paints can be avoided by not applying paint in the evening of cool spring and fall days when heavy dew can form before the surface of the paint has thoroughly dried. Serious water absorption problems and major finish failure can also occur with some latex paints when applied under these conditions. Allow the paint to dry for at least 2 hours before sunset. Likewise, do not begin painting in the morning until the dew has had time to evaporate.

Solid-Color Stains

Solid-color stains may be applied to a smooth surface by brush, roller, or pad application, but brush application is usually the best. These stains act much like paint. However, they are not generally recommended for horizontal wood surfaces such as decks, railings, fences, and window sills. One coat of solid-color stain is adequate, but two coats will always provide better protection and longer service. The all-acrylic latex solid-color stains are generally superior to all others, especially when two coats are applied. Oil-based solid-color stains are often used as the first coat over staining-type woods such as cedar and redwood.

Unlike paint, a solid-color stain may leave lap marks. Latex-based stains are fast-drying and are more likely to show lap marks than are oil-based stains. To prevent lap marks, follow the procedures suggested under application of semitransparent penetrating stains.

Natural Finishes

Water-Repellent Preservatives

The most effective method of applying a water-repellent preservative is to dip the entire board into the solution. However, brush treatment is also effective. When wood is treated in place, liberal amounts of the solution should be applied to all lap and butt joints, edges and ends of boards, and edges of panels where end grain occurs. Other areas especially vulnerable to

moisture, such as the bottoms of doors and window frames, should not be overlooked. One gallon of preservative will cover about 250 ft² of smooth surface or 100 to 150 ft² of rough surface. When used as a natural finish, the life expectancy of preservative on new wood is only 1 to 2 years, depending upon the wood and exposure (see Table 7). Treatments on rough surfaces are generally longer lived than those on smooth surfaces. Repeated brush treatment to the point of refusal will enhance the finish durability and performance.

Weathering of the wood surface may be beneficial for both water-repellent preservatives and semitransparent penetrating stains. Weathering opens up checks and cracks, thus allowing the wood to absorb and retain more preservative or stain, so the finish is generally more durable. However, much more finish will be required than if the wood were not weathered.

Oils

Oils should be applied in the same way as semitransparent penetrating stains. Care should be used in handling cloths used to apply the oils.

Semitransparent Penetrating Stains

Semitransparent penetrating stains may be applied by brush, spray, or roller. Again, brushing will usually give better penetration and performance. Spraying followed by back brushing is also a good method of application. These oil-based stains are generally thin and runny, so application can be messy. Lap marks will form if stains are improperly applied (Fig. 26). Lap marks can be prevented by staining only a small number of boards or a panel at a time. This method prevents the front edge of the stained area from drying out before a logical stopping place is reached. Working in the shade is desirable because the drying rate is slower. One gallon will usually cover about 200 to 400 ft² of smooth surface and from 100 to 200 ft² of rough or weathered surface.

To achieve a long life for penetrating, oil-based stain on roughsawn or weathered lumber or plywood, use two coats and apply the second coat before the first is dry. Apply the first coat to one panel or area. Then work on another area so that the first coat can soak into the wood for 20 to 60 minutes. Next, apply the second coat before the first has dried. (If the first coat dries completely, the second coat cannot penetrate into the wood.) Finally, about an hour after applying the second coat, use a cloth, sponge, or dry brush, lightly wetted with stain, to remove the excess stain. Otherwise, the stain that did not penetrate the wood will form an unsightly surface film and glossy spots. Stir stain



Figure 26---Lap marks formed by improper application of a semitransparent penetrating stain

thoroughly during application to prevent settling and color change. Avoid mixing different brands or batches of stain.

For oil-based stains, a two-coat wet system on rough wood or plywood may last as long as 8 years in certain exposures. By comparison, if only one coat is applied on new, smooth wood, its expected life is 2 to 4 years; life expectancy is less on woods like western redcedar. However, succeeding coats will usually last longer because more stain can be applied.

CAUTION: Sponges or cloths that are wet with oil-based stain are particularly susceptible to spontaneous combustion. To prevent fires, bury the cloths, immerse in water, or seal in an airtight container immediately after use.

Latex semitransparent stains do not penetrate the wood surface but are easy to apply and less likely to form lap marks. For a long life, two coats should be applied. Apply the second coat anytime after the first has dried. The second coat will remain free of gloss, even on smooth wood. These stains are essentially very thin paints and perform accordingly. New formulations are being developed that may have some penetrating characteristics.

Transparent Film-Forming Coatings

Although short lived, transparent film-forming coatings such as high-quality polyurethane or spar varnish are occasionally used for exterior applications. The wood surface should be clean, smooth, and dry before application of the coating. The wood should first be treated with a paintable water-repellent preservative as discussed under painting procedures. The use of varnish-compatible, durable, pigmented stains and sealers or undercoats will help to extend the life of the finishing system. At least three topcoats should be applied. However, the life expectancy of the coatings on fully exposed surfaces is only 2 years at best. In marine exposures, six coats of varnish should be used for best performance. Varnish built up in many thin coats (as many as six) with a light sanding and a fresh coat added each year will usually perform the best.

Special Applications

Although general wood-finishing procedures are applicable to typical situations, some applications deserve special mention. These include the application of finish to decks and porches, fences, wood roofs, log structures, and structures in marine environments. Wood used in all of these applications is usually

exposed to particularly harsh weathering conditions. Special consideration should be given to finish selection and application. Log structures also need special consideration because of the large amounts of end grain exposed and the deep checking associated with large timbers as well as small, round logs.

Decks and Porches

Decks and porches present a particularly severe exposure for wood and finishes. Most wood members are in a horizontal or flat position. These horizontal surfaces, especially in decks, are often exposed to the direct rays of the sun and tend to collect moisture, so the weathering process is greatly accelerated. As wetting and drying occurs, checks tend to enlarge rapidly into cracks and, along with the end-grain surfaces, tend to retain moisture. The conditions for decay and insect attack caused by the presence of moisture are thereby greatly improved. Any film-forming finish is subjected to excessive stress because of the continuous shrinking and swelling of the wood that results from changes in moisture content. Furthermore, the finish is subjected to abrasive wear, particularly in high-traffic areas. Porches are usually somewhat protected, so the conditions are not normally as severe as those with decks; however, the same conditions—moisture, sun, and abrasive wear—are usually present at least periodically. Fully enclosed porches are generally not subject to weathering problems.

As a result of severe weathering conditions, lumber that has been pressure treated with waterborne preservatives, or naturally durable wood such as redwood, is generally used, at least on decks. These materials may be left to weather naturally or finished in a number of ways.

For fully exposed decks, a water-repellent preservative or a semitransparent penetrating stain may provide the best finishing solution, even on wood that has been pressure treated with preservatives. Special formulations specifically made for decks are available. These penetrating deck finishes, at least the water-repellent preservatives, may be shorter lived than paint, but they are more easily renewed. For severe exposures, the finish should be renewed annually; spring is usually the best time. Light-colored penetrating stains will also last longer than dark ones on flat surfaces subject to traffic because light stains show the least contrast in grain color as wear occurs. The penetrating finishes need to be refinished every 1 to 2 years. To refinish, a simple cleaning of the wood with a bristle brush is usually adequate before applying the water-repellent or penetrating finish. Paint and solid-color stains, particularly in these applications, are likely to peel. Laborious scrap-

ing and sanding before refinishing will usually be required for such finishes. Thus, paint and solid-color stains are not appropriate for fully exposed decks.

The bright color of the wood on weathered decks can be restored by application of commercial products (called deck cleaners, brighteners, or restorers). These products may remove the weathered wood surface and some care should be exercised not to remove excess wood. Color can also be restored using a liquid household bleach containing 5 percent sodium hypochlorite. The bleach is usually diluted with water (1 part bleach, 3 parts water) before it is applied to the deck. The bleach solution should be rinsed from the deck with water. If the deck is to be finished after cleaning, allow 1 or 2 days drying time.

Paint may be used successfully on roof-protected porch floors. The best procedure is to treat the wood with a paintable water-repellent preservative. After the floor dries, a primer and topcoats of porch and deck enamel should be applied. Porch enamel is especially formulated to resist abrasion and wear. Because of their low resin content, solid-color stains should never be used on flat surfaces such as decks and porches.

Fences

Like decks, fences are fully exposed to the weather and have at least some parts in soil contact. As a result, wood decay and termite attack are potential problems. Care must be exercised in selecting and applying a finish to obtain a reasonable service life. This is especially true in the South.

For maximum service life, all wood fence posts used in the South must be pressure treated with a wood preservative. Although boards and rails may be of naturally durable species, pressure-treated wood will last longer because of the severity of exposure and the variability of naturally decay-resistant species. Both treated and untreated wood should be treated with a water repellent or water-repellent preservative. Be sure to liberally treat the ends and the places where pieces of wood are in contact.

Hot-dipped galvanized, stainless steel, or aluminum nails should be used wherever possible. Some aluminum nails are soft and will bend when used on dense woods such as southern yellow pine. These types of nails will prevent rust staining and also the possible formation of blue-black discoloration should a water-repellent preservative or semitransparent penetrating stain be used.

Many fences are left to weather naturally. However, if a finish is desired, semitransparent penetrating stains



Figure 27---Commercial structure with wood shingle roof. (Photo courtesy of Southern Forest Products Association.)

or water-repellent preservatives that contain a mildewcide or are otherwise resistant to mildew are preferred. These finishes soak into the wood without forming a film, and thus they do not crack or peel. Stains come in a variety of colors and show the wood grain. If paint is to be used, brush the surface and all ends and joints liberally with a paintable water-repellent preservative and let the surface dry for at least 2 warm, sunny days before painting. Use one coat of a good-quality stain-blocking acrylic latex primer, followed by two topcoats of a good-quality acrylic latex exterior house paint. When repainting, scrape all loose paint from the wood, then use a stiff bristle brush to remove any remaining loose paint and dirt. Next, brush on a paintable water-repellent preservative. Apply it liberally to ends of boards or pickets and to all joints. Let the treated wood dry and then paint with acrylic latex paint.

Varnish finishes and solid-color stains are not recommended for exterior fences because they will not withstand sun and rain and will require frequent refinishing.

Roofs

Although wood shingles and shakes have been largely replaced on standard buildings by composition or asphalt-based shingles, their use is still widespread on commercial structures and houses (Figs. 27 and 28). Shingles are sawed from large blocks of wood, are tapered from one end to the other, and generally have a relatively smooth surface. Shakes are split from larger blocks of wood and thus have a more rugged appearance. Shakes may be approximately the same thickness on both ends, or they may be sawed from corner to corner, thus providing taper as well as one relatively smooth side, which is turned down during installation. Shakes may also have a grooved appearance. Shingles and shakes are used *on* sidewalls as well as roofs and may be preservative or fire-retardant treated.

Wood properties. Wood used in the manufacture of shingles should have the following properties: (1) durability, (2) freedom from splitting during nailing, (3) dimensional stability, that is, low ratio of tangential to radial



Figure 28—Log house with wood shake roof.

shrinkage and minimum shrinkage in all planes, (4) light weight, (5) good insulating properties, (6) adequate strength, (7) straight, even grain for ease of manufacture, (8) ability to take stains, (9) ability to resist abrasion, and (10) pleasing appearance. Edge-grained shingles will perform much better than flat-grained. Western redcedar, redwood, cypress, and northern and southern white cedars all possess the desired properties, but nearly all commercial shingles are currently produced from western redcedar.

Of all wood properties to be considered, durability is probably the most important. The heartwood of old-growth western redcedar is rated as extremely durable. The generally small amount of sapwood associated with this species is nondurable. There is a general consensus that some second-growth timber, even of the decay-resistant species, is not as durable as the old growth. The durability of the wood will also be decreased as rain or other sources of moisture leach the extractives from the wood. The heartwood extractives provide cedar with natural decay resistance. The average service life of a cedar shingle roof in the South is estimated to be about 10 to 15 years, whereas a shake roof will last an average of 15 to 20 years.

In addition to western redcedar, southern yellow pine taper-sawn shingles may be available. Research has shown that this species can be manufactured into wood shingles and pressure treated with a wood preservative. A roof free of decay for 25 to 30 years should result. Other species may also be used for shingles if properly treated or naturally durable.

Application of shingles and shakes. Regardless of the type of finish, if any, proper application of shingles and shakes is required if a long life is to be expected. Because roofs are directly exposed to moisture and rain, use only the top grade of shingles or shakes manufactured with edge-grained heartwood (or treated sapwood). Lower grades can be used on sidewalls or where an undercourse is required. Some factors to consider when applying shingles are (1) the decking to which the shingles are nailed, (2) the number, location, and type of nails, (3) the head lap or amount of lap over the course below (which often depends on shingle grade and application), (4) the space between the edges of the shingles or shakes, and (5) the separation of edge joints from one course to another. The Red Cedar Shingle and Handsplit Shake Bureau (515 116th Avenue NE, Suite 275, Bellevue, WA 98004) provides an excellent publication containing details on shingle

and shake grades and application procedures. Similar information on CCA-treated southern pine shakes is available from the Southern Forest Products Association, P.O. Box 52468, New Orleans, LA 70152.

Application of finish. Shingles and shakes, whether on a roof or sidewall, are often left to weather naturally if they are made from a durable species such as western redcedar. Depending on exposure and climatic conditions, the wood generally turns silver, dark gray, or dark brown. However, in warm, humid climates common to the South and on heavily shaded roofs and sidewalls, mildew, moss, algae, lichens, and even wood decay can occur with time. For these reasons and for esthetic effects, various finishes and preservatives can be applied to wood shingles and shakes to obtain a particular color. The types of finishes used on sidewalls may differ substantially from those used on roofs.

Weather will rapidly deteriorate any finishing system. In addition, construction methods contribute to the conditions that encourage finish and wood deterioration. Because large quantities of end grain are exposed on shingles and shakes, the wood rapidly absorbs moisture, resulting in excessive shrinking and swelling. Because moisture tends to migrate from the living quarters to the outside of a house, shingles and shakes can also absorb moisture from their back side. Furthermore, when film-forming finishes are applied to in-place roofs, small dams of finish form across the bottom of the gaps between shingles, which adds to the amount of water absorbed by the back of the shingle. Adequate attic ventilation and sidewall vapor barriers should be provided.

As a result of these potential problems, film-forming finishes, such as paint, solid-color stains, and varnish or other clear, film-forming finishes should never be used on roofs. A transparent finish such as varnish will deteriorate within a few months, while a pigmented finish such as paint will usually last only a few years. The result will be an unsightly appearance that is difficult to refinish. Increased wood decay is also likely because the film-forming finish can help to retain moisture in the shingle or shake. Paint and solid-color stains can sometimes be used on shake or shingle sidewalls with better results.

If roofs or sidewalls are to be finished, semitransparent penetrating oil-based stains provide the best performance. These stains provide color without entirely concealing the grain and texture of the wood. They are relatively long lived and easily renewed, and may last several years on roofs and considerably longer on sidewalls. Rough-textured edge-grained surfaces give longer service life than do smooth surfaces. The

semitransparent stain should contain a wood preservative and a mildewcide. Some paints and stains are specially formulated for use on shingles. Those with the highest concentration of pigment will likely give the longest service life. Water-repellent preservatives may also be used on roofs and sidewalls, although their life expectancy on sidewalls is only 2 to 3 years; life expectancy is even less on roofs unless the treatments are specially formulated. These finishes contain a wax or other water repellent, a preservative, and a solvent or carrier.

The first coat of finish is best applied to shingles before they are installed so that the backs and butts as well as the faces are thoroughly coated. The finish may be applied by dipping the shingles to at least two-thirds their length and then standing them vertically until the finish has dried. In addition to dipping, the finish may be applied by brushing, rolling, or spraying. Dipping is the most effective method, followed by brushing. If the backs are not finished, seepage of rainwater under the shingles may cause more curling than would otherwise take place. If a light-colored finish has been applied, the butts and edges of the shingles may be discolored by water-soluble extractives from the wood. Any additional coats may be applied by brushing or spraying after the shingles have been installed. Care should be taken to coat the exposed butt ends with the finish thoroughly, preferably by brushing.

Preservatives and fire retardants. In some cases, particularly where warm temperatures and humid conditions persist for substantial parts of the year, it is desirable to extend the life of wood shingles and shakes with special preservative treatments or fire retardants. For maximum effectiveness and long life, shingles and shakes pressure treated with these chemicals should be purchased. Chromated copper arsenate (CCA, Type C), copper-8-quinolinolate, and copper naphthenate are all effective wood preservatives when properly applied.

Maintenance. Leaves and other debris that often accumulate on roofs, particularly in roof valleys and gutters, will trap moisture in shingles, increasing the likelihood of decay. Therefore, loose debris should be routinely cleaned from roofs and gutters. Overhanging limbs and vines that provide excessive shade should also be removed.

The roof should be checked for moss or lichen growth and be chemically treated if necessary. One simple method to prevent moss from developing on roofs is to use zinc, galvanized, or copper flashings. The normal corrosion from these metals, when stretched along the butt end of the shingles, will provide some control of moss (plus mold and mildew) for about 10 to 15 ft

downslope from the metal. Treating the roof with selected chemicals can also provide some protection. A solution of copper naphthenate with 3 to 4 percent metal content, copper octoate with 1 to 2 percent metal content, copper-8-quinolate with about 1 percent active ingredient content, or other preservatives can be used to control moss, lichens, and surface decay and to prevent their growth for some time. Solutions are best applied by brushing or dipping. Commercial formulations for roof treatment are available.

NOTE Manufacturers' application end safety recommendations should be followed because wood preservatives can be toxic to plants and to humans if used improperly. Humans, animals, and vegetation should be protected from drippings and runoff from the roof or gutters.

Regardless of the method used, surface treatments are limited to the surface of shingles. They will not prevent serious decay problems within the shingle or unexposed parts of the roof that are not treated. However, in some cases, surface treatments can help to lengthen the life of a wood roof by preventing the growth of moss and lichens, which retain moisture in the wood and thereby promote wood decay.

Log Structures

Interest in the construction of new log structure (Fig. 28) as well as maintenance and restoration of old ones has increased dramatically in recent years. These structures present some unique problems and opportunities for maintenance and finishing. However, before a finish is even considered, the structure must be carefully built to keep the outside wood surface as dry as possible. Good construction practices include (1) adequate roof overhang with properly hung and maintained gutters and downspouts; (2) roof vents, if attic space is present (3) good drainage and ventilation around the foundation; (4) proper venting of showers, baths, and dryers; (5) adequate clearance between the soil and lower logs; and (6) most important of all, proper log design so that any moisture will run down and off the log rather than become trapped. Trapped moisture is certain to result in wood decay. Old structures that are still sound were usually constructed with attention to these moisture-proofing details. Also, naturally durable woods such as white oak, walnut, heartwood of white pine, and cedar were usually used, particularly for the lower courses of logs. However, even these woods will succumb to decay with prolonged exposure to moisture.

Log houses are particularly susceptible to decay because of the deep seasoning checks that occur on the surface of large wood members. These checks

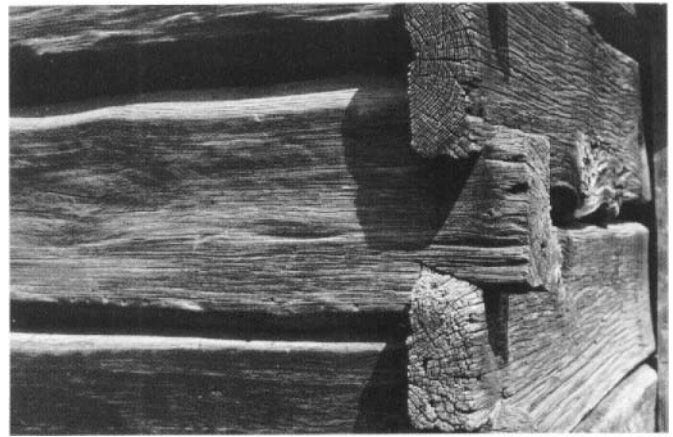

Figure 29---Deep checks on an old log structure retain moisture and encourage decay.

allow moisture to penetrate into the wood member, and decay results. Excessive end grain is also exposed, particularly on the corners of log structures (Fig. 29). This end grain as well as the notching of the logs allows for easy penetration of moisture and subsequent decay. Proper construction, particularly wide roof overhangs, and the application of preservative finishes can help to reduce or eliminate problems.

Because log houses are usually rustic in appearance, non-film-forming (penetrating) natural finishes are preferable to film-forming finishes. Water-repellent preservatives liberally applied every couple of years will allow a new wood surface to weather to light brown or tan. The preservative will also help prevent decay should water penetrate the surface checks and cracks or end grain. However, it will not prevent decay where poor construction practices allow repeated wetting or condensation. Deep surface cracks, lower courses of logs, joints between logs, corners of the structure, and bottoms of windows and doors often trap moisture and are particularly vulnerable to decay. Consequently, these areas should be treated liberally.

Semitransparent penetrating stains may also be used if a longer service life for the finish is preferred, if a color other than light brown or tan is desired, and if partial covering of the wood grain is not objectionable. Stains containing preservatives or mildewcides and water repellents are desirable for best performance.

If the structure to be finished requires chinking, apply the finish and preservative before chinking. In this way, the tops of the logs, which are particularly vulnerable to wetting and subsequent decay, can be treated and the chinking will not be stained accidentally during finish application.

For existing structures, even those that are well weathered, the application of a water-repellent preservative

can help prevent further deterioration. Any decayed wood should be removed and the newly exposed wood liberally treated after the moisture source has been eliminated and the wood dried. To facilitate treatment of hard-to-reach areas that may have some decay, 1/4-in. holes can be drilled in the wood and filled, preferably several times, with preservative solution that will diffuse into the adjacent wood. The holes should then be plugged with preservative-treated wood dowels.

NOTE: Most preservatives should not be used indoors. Always check manufacturer's recommendations and Material Safety Data Sheets for proper use of all preservatives.

The use of borates to control wood decay is a relatively new development in the United States and may be particularly useful on log structures with moisture problems. The material is manufactured for brush or spray application or as a "rod" that can be inserted into holes bored in the wood. The material diffuses through wet wood and provides protection against decay and wood-destroying insects. This material will probably be available through distributors and can be applied by professionals such as pest control operators, log cabin manufacturers, and pole treaters.

Structures in Marine Environments

The marine environment is particularly harsh on wood finishes because of the abundance of moisture and exposure to full sunlight. The natural weathering process of wood and finishes is accelerated.

For best protection, any wood fully exposed to marine environments, especially if it is in contact with the water or soil, should be pressure treated with a wood preservative. The treatment should be based on applicable marine or in-ground use specifications and local-use experience. Such treated woods are not always paintable. However, wood treated with waterborne preservatives is paintable when clean and dry. Chromated copper arsenate (CCA) is the most paintable of the waterborne preservatives. Protected wood, in which serious wood decay is not expected to occur, can be treated with a paintable water-repellent preservative, coated with a suitable paint primer, and topcoated with at least two coats of quality, exterior finish. Oils and other penetrating natural finishes will need to be reapplied at least annually and often semiannually, depending on exposure conditions. Antifouling paints can be used for protection against marine organisms on piers and boat hulls.

Natural film-forming finishes (varnishes) for woods exposed to marine environments need almost constant care and refinishing. If used, varnishes should be

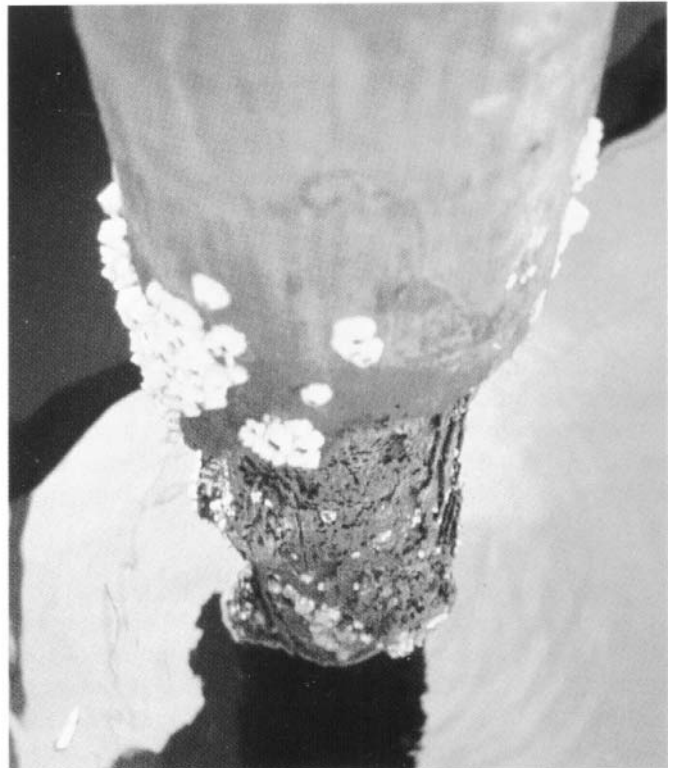

Figure 30---Extensive damage to a wooden waterfront structure from marine borers (*Limnoria*).

applied in three- to six-coat thicknesses for best performance. The application of a paintable water-repellent preservative or pigmented, varnish-compatible stain before finishing will help improve the performance of the varnish.

Wood used in salt or brackish water can also be damaged by marine borers (Fig. 30). Marine borers are serious pests in wooden waterfront structures and have damaged wooden vessels throughout history. The marine borers that cause the greatest amount of damage can be divided into two main groups: Mollusca and Crustacea. Molluscs are shell animals like clams and oysters. Molluscan borers are divided into two families, Teredinidae and Pholadidae. Teredinidae contains the genera *Teredo* and *Bankia*, commonly called wood-boring shipworms. Pholadidae includes the genus *Martesia* and resembles clams. This family is commonly referred to as Pholads or rock-boring piddock. Marine borers in the phylum Crustacea are related to lobsters and crabs. *Limnoria* and *Sphaeroma* are important wood-destroying genera in this group of borers. *Limnoria* are commonly referred to as gribbles.

Marine borers vary greatly in their distribution and ability to destroy wood. They are generally more destructive in tropical waters. Their population can rise

and fall depending on any number of factors such as salinity changes resulting from floods or other causes, water temperatures, and dissolved oxygen content. There is some indication that marine borer populations increase as pollution levels decline. Because of the variation in marine borers, consult local authorities before purchasing wood that will be placed in salt or brackish water.

Treated Wood

Preservatives

Lumber, plywood, and other wood products pressure treated with preservatives do not normally require finishing for outdoor exposure. However, if a finish is desired for esthetic reasons, certain precautions should be exercised because each of the three classes of wood preservatives imparts certain characteristics to the wood that affect its ability to accept and retain a finish. The general classes of wood preservatives are (1) preservative oils such as coal-tar creosote, (2) organic solvent solutions such as pentachlorophenol, and (3) waterborne preservatives.

When coal-tar creosote or pentachlorophenol in a heavy oil solvent with low volatility is used to pressure treat wood, successful finishing is impossible. The surface is generally oily and dark, and the dark color will usually bleed through any paint. Poor adhesion is also likely. If the wood has weathered for years, it can sometimes be stained or painted, but it is best to finish a small area first and expose it to direct sunlight to determine if the finish would perform well.

When wood has been pressure treated with pentachlorophenol in a highly volatile solvent such as methylene chloride or liquefied petroleum gas, its surface can still generally be painted but only after the solvent has completely evaporated. However, solvents vary in their volatility, and the evaporation period may take from 1 to 2 years. Even with special drying schedules, the complete paintability of the wood may not be restored. Similarly, wood that is pressure treated with a water-repellent preservative is loaded with relatively large quantities of the preservative and solvent, and the solvent must be completely removed before painting is attempted. This process, however, should not be confused with the brush, spray, or dip treatment of a water-repellent preservative, which serves to enhance paint durability and wood performance.

Coal-tar creosote and pentachlorophenol are restricted-use pesticides and therefore the solutions are not available to the general public. However, wood treated with these preservatives is available either as new or used material, such as railroad ties and poles. The

Consumer Information Sheets of the Environmental Protection Agency specify that wood treated with either of these preservatives should not be used where frequent or prolonged contact with the skin will occur or in residential, industrial, or commercial interiors, except for laminated beams or building components that are in ground contact. When used in these applications, two coats of an appropriate sealer are required. Because of these restrictions, coal-tar creosote and pentachlorophenol are not now commonly used in or around residential or commercial buildings.

Waterborne preservatives, such as chromated copper arsenate (CCA), are the only common preservative chemicals applied by a pressure process that do not adversely affect the wood finishing characteristics. In fact, those preservatives that contain chromium reduce the degrading effect of weathering. Lumber or plywood treated in this manner can be finished following normal procedures or allowed to slowly weather to a light gray. Water-repellent treatments should be used for decks and fences. This treatment will help reduce surface checking and cracking.

Most pressure-treated construction lumber and plywood in the southeastern United States is produced from southern yellow pine with flat-grained characteristics and wide latewood bands. Because of the relatively poor paint-holding properties of this species group, semitransparent oil-based penetrating stains or other penetrating finishes will give better service than will other finishes. The finish should be applied after the wood has thoroughly dried. Drying may take days or weeks depending on how wet the wood is initially and on drying conditions.

Wood that is pressure treated with waterborne preservatives generally contains large quantities of water when shipped to retail lumber yards. Therefore, care should be exercised to make certain that the lumber is dry before finishing. Air drying in place is acceptable, although some shrinking, warping, and checking may result. Regardless of the finish to be applied, the recommended procedures for its application should be followed carefully, and the wood should be completely clean.

NOTE: The Environmental Protection Agency (EPA) has issued consumer information sheets on each of the three general classes of wood preservatives; creosote, pentachlorophenol, and the inorganic arsenical, which include chromated copper arsenate (CCA), ammoniacal copper arsenate (ACA), and ammoniacal copper zinc arsenate (ACZA). The consumer information sheet on arsenical is included as Appendix B.

For maximum service life, wood items used outdoors, such as lawn furniture, playground equipment, planters, and retaining walls, should be pressure treated with a preservative before finishing, especially if the item is in soil contact. Naturally durable woods may be suitable for mild exposures. Water-repellent preservatives and semitransparent penetrating stains will generally provide the longest service life coupled with ease of refinishing.

Caution: For items where human contact is likely or where food will be served, make certain that the wood preservative and finishing system is acceptable for that application.

Fire-Retardant Treatments

Treating wood with fire retardants should not interfere with adhesion of decorative paint coatings unless the hygroscopicity of the wood has been increased because of the nature of the chemical used. Only those fire-retardant treatments specifically prepared and recommended for outdoor exposure should be used outdoors; others may leach from the wood, causing discoloration and early paint failure. Treated woods are generally painted according to the manufacturer's recommendations rather than left unfinished because the chemical treatment and subsequent kiln-drying process often darken and irregularly stain the wood.

Southern yellow pine and Douglas-fir are two species commonly treated with fire-retardant chemicals. Because these species normally do not hold paint or solid-color stains well, strict adherence to recommended finishing procedures should be followed. Treated western hemlock and ponderosa pine have somewhat better finishing characteristics than those of southern yellow pine and Douglas-fir.

Because of the variability of wood preservatives and fire retardants as well as the nature of the treating processes, the manufacturer should be consulted regarding finishing details. The manufacturer usually has specific recommendations for achieving maximum service life for paint and other finishes. Wood treated in strict adherence to recognized standards should contain a quality stamp indicating the treatment, treating company, and inspection bureau.

Refinishing of Wood

Exterior wood surfaces should be refinished only as the old finish deteriorates or for esthetic reasons such as a change in color or type of finish. Too frequent refinishing, especially with paint, leads to a finish buildup and subsequent cracking and peeling. In some cases, dirty

painted surfaces can be cleaned by washing with a mild detergent and water. To achieve maximum service life from a refinished surface, special surface preparation and finish application techniques should be followed.

Opaque Finishes

In refinishing an old paint coat or a solid-color stain that has weathered normally, proper surface preparation and cleaning are essential for optimal performance of the new finish. If the surface had been finished with a lead-based paint, be sure to follow necessary precautions for preparing the surface (see section on lead-based paint).

Latex paint can be applied to weathered painted surfaces if the old paint is clear and sound. The paintability of the surface can be tested with a simple procedure. After cleaning the surface, refinish a small, inconspicuous area with latex paint, and allow it to dry at least overnight. To test for adhesion, firmly press one end of an adhesive bandage onto the painted surface. Then, jerk the bandage off with a snapping action. If the tape is free of paint, the paint is well bonded and the old surface does not need to be primed or cleaned (Fig. 31). If the paint adheres to the tape, the old surface is too chalky and needs priming with an oil-based primer or additional cleaning. The primer should penetrate the old chalky surface and form a firm base for the new coat of paint. If both the freshly applied paint and the old paint coat adhere to the tape, the old paint is not well bonded to the wood and must be removed before repainting the surface.

To refinish the old surface, first scrape away all loose coating. Sand any remaining coating to "feather" the edges smooth with the bare wood. Then, scrub remaining coating with a brush or sponge and water. Rinse the scrubbed surface with clean water. Wipe the surface with your hand. If the surface is still dirty or chalky, scrub it again with a detergent. Mildew should be removed with a dilute solution of household bleach. Rinse the cleaned surface thoroughly with fresh water and allow it to dry before recoating. Areas of exposed wood should be treated with a water-repellent preservative and allowed to dry for at least two sunny days and then primed. Wipe away any water-repellent preservative accidentally applied to coated areas. Apply topcoat or topcoats. When refinishing with oil-based coatings, one topcoat is usually adequate if the old surface is still in good condition.

It is particularly important to clean areas protected from sun and rain such as porches and sidewalls with wide roof overhangs. These areas tend to collect dirt and water-soluble materials that interfere with adhesion of

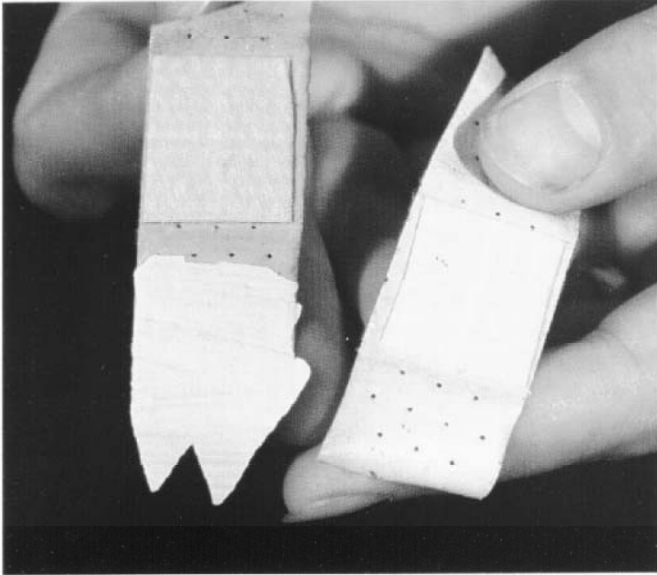

Figure 31—The adhesive bandage test can be used to determine if a new coat of paint is properly bonded to an old surface. The bandage on the right was applied to a well-bonded paint coat, the bandage on the left to a poorly bonded paint coat.

the new coating. Protected areas can be refinished every other time exposed areas of the house are refinished.

Natural Finishes

Water-Repellent Preservatives

Water-repellent preservatives can be renewed by a simple cleaning of the old surface with a bristle brush and application of a new coat of finish. In some cases, a mild scrubbing with a detergent followed by rinsing with water is appropriate. The second coat of water-repellent preservative will last longer than the first; more preservative can be applied because of small surface checks that are created by weathering.

Before renewing a water-repellent preservative, make certain that there is no mildew on the old surface. If mildew is present, it can grow through the new coating. See section on prevention and removal of mildew.

To determine if a water-repellent preservative has lost its effectiveness, splash a small quantity of water against the wood surface. If the water beads up and runs off the surface and does not penetrate it, the treatment is still effective. If the water soaks in, the wood may or may not need to be refinished. Sometimes a water-repellent preservative breaks down at the surface but is still effective. In this case, the surface of the wood appears wet (dark) but the moisture does not penetrate deeply. Refinishing is also required when

the wood surface starts to show blotchy discoloration caused by extractives or mildew.

Oils

Oil finishes can be renewed following the suggestions given for water-repellent preservatives.

Semitransparent Penetrating Stains

Semitransparent penetrating stains are relatively easy to refinish. Excessive scraping and sanding are not required—simply use a stiff bristle brush to remove all surface dirt, dust, and loose wood fibers, and then apply a new coat of stain. The second coat of penetrating stain often lasts longer than the first because more can be applied.

Note: Steel wool and wire brushes should never be used to clean surfaces to be finished with semitransparent stains, oils, or water-repellent preservatives because small iron deposits may be left on the surfaces. These deposits can react with certain water-soluble extractives in wood like western redcedar, redwood, Douglas-fir, and the oaks to produce dark blue-black stains on the surface. In addition, additives present in some semitransparent penetrating stains and water-repellent preservatives may cause surface iron to corrode. The corrosion products may then react with certain wood extractives to form a blue-black, unsightly discoloration that becomes sealed beneath the new finishing system.

Transparent Film-Forming Coatings

The refinishing practices described for opaque coatings should generally be followed for transparent, film-forming finishes such as varnish. For oils and similar penetrating finishes, follow the practices recommended for water-repellent preservatives.

Removal of Finish

The removal of paint and other film-forming finishes is a time-consuming and often difficult process. However, it is sometimes necessary for the preparation of a new surface if, for example, the old surface is covered with severely peeled or blistered paint, or if cross-grain cracking has occurred from excessive paint buildup. The removal of finish is also necessary if a penetrating stain or water-repellent finish is to be applied to a previously painted or stained (solid-color) surface. Finishes can be removed by sanding, sandblasting, spraying with pressurized water, using electrically heated paint removers and blow torches, or stripping with chemicals. Consult with local equipment-rental

stores and paint dealers for available equipment, or request bids from professional contractors. **Before proceeding, be sure to review the section on the identification of health hazards associated with the removal of lead-based paints.**

Sanding

Disk or siding sanders equipped with a tungsten carbide abrasive disk of medium grit are effective in removing old paint. This method is faster than others, and the tungsten carbide disk is less likely to clog compared to conventional sanding disks. The depth of cut for the sander can be set with the siding guide, but experienced operators often work freehand, without the guide. The operator should be careful to remove only the paint and not excess wood. After finishing with the disk sander, it is desirable to smooth the surface somewhat by light manual sanding or with a straight-line power sander using 120 grit in the direction of the wood grain.

Wet Sandblasting and Pressurized Water Spray

Paint can also be removed by blasting with wet sand or using a high-pressure water spray. These methods usually require the services of a professional. The sand particles or water can erode the wood as well as strip the paint. The softer earlywood is eroded faster than the latewood, resulting in an uneven, rough surface. These rough surfaces may not be suitable for painting. The pressurized water spray method uses approximately 600 to 2,000 pounds of pressure per square inch.

Caution: Some old paints contain lead, and sanding, sandblasting, or disturbing the surface in any way will release tiny lead particles into the air. Inhalation of these lead particles is detrimental to health. Be sure to read the section on lead-based paints. For the sake of safety, anyone sandblasting or using pressurized water spray equipment should wear approved eye goggles as well as a dust mask or respirator, as appropriate. Electrical equipment should be double insulated or equipped with a three-wire grounded outlet.

Heat

Electrically heated paint removers can be used to strip paint. The heater simply heats and softens the paint, causing it to separate from the wood. This method, although effective, is slower than sanding and requires at least a 1,000-W heater to be effective. Paint can also be removed with an open-flame blowtorch. A blowtorch is effective and inexpensive. **However, there is a constant danger of starting a fire within**

the walls of the building from flames that penetrate cracks in the siding. This method is usually best done by professionals.

Chemicals

Liquid paint and varnish removers, such as commercially prepared chemical mixtures, lye, or trisodium phosphate, will also remove paint from wood surfaces. After the paint is removed, the surface sometimes must be neutralized; before repainting, the wood surface should be sanded in the direction of the grain. Strong caustic solutions, such as lye and trisodium phosphate, may leave the wood surface very porous.

Failure or Discoloration of Finish

Paint properly applied and exposed under normal conditions is usually not affected by the first 2 to 3 years of exposure. Areas that deteriorate the fastest are those exposed to the greatest amount of sun and rain, usually on the south and west sides of a building.

Under normal conditions, paint deteriorates first by soiling or accumulating slight traces of dirt. Next, the coating gradually starts to chalk and erode away. Paint can sometimes become discolored by mildew, blue stain, wood extractives, pitch, and metals, making repainting necessary. In these cases, however, a simple repainting will not correct the problem for long. Furthermore, frequent repainting is expensive, and a buildup of paint on the wood surface may lead to cross-grain cracking or other severe paint failures. If the old paint surface is not properly cleaned before repainting, intercoat peeling may also result. Paint may also peel from poor construction practices that allow excess moisture buildup in the wood. Iron and water stain may be a problem when natural finishes are applied and poor construction practices have been followed.

Finish failure or discoloration can be eliminated only by identifying and correcting the problem. Refinishing without correcting the original problem will result in repeated failure of the finish.

Mildew

Mildew is probably the most common cause of discoloration of house paint, solid-color and semitransparent stains, and natural finishes (Fig. 32). It also causes the gray discoloration of unfinished wood. The term mildew applies both to the fungus (a type of microscopic plant life) and to its staining effects on the substrate (the substance on which it grows; in this case, the coating and the wood). Mildew grows on the



Figure 32—Mildew on paint is most common in warm, humid climates. It also occurs in shaded or protected areas.

paint or wood surface and does not normally degrade the wood as do wood-rotting fungi. The most common mildew species are black, but some are brown, red, green, or other colors. Mildew grows most extensively in warm, humid climates. Although mildew may be found anywhere on a building, whether or not the building is painted, it is most commonly found on walls behind trees or shrubs where air movement is restricted. Mildew may also be associated with the dew pattern of the house. Dew will form on those parts of the house that are not heated and tend to cool rapidly, such as eaves, the ceilings of carports and porches, and the wall area between studs. The dew provides a source of moisture for the mildew.

Mildew can be distinguished from dirt by examination under a high-power magnifying glass. In the growing stage, when the paint surface is damp or wet, a mildew fungus is characterized by its threadlike growth. In the dormant stage, when the surface is dry, the fungus has many egg-shaped spores. By contrast, granular particles of dirt are irregular in size and shape. A simple test for the presence of mildew on paint and wood can be made by applying a drop or two of a fresh solution of household liquid bleach (5 percent sodium hypochlorite) to the stained area. The dark color of mildew will usually bleach out in 1 or 2 minutes. Discoloration that does not bleach out is probably dirt. Fresh bleach solution should be used because the solution deteriorates upon standing and loses its potency.

Effect of Paint Makeup

Some paints are more vulnerable than others to attack by mildew fungi. Zinc oxide, a common paint pigment

in topcoats, inhibits the growth of mildew (that is, acts as a mildewstat), whereas titanium dioxide, another common paint pigment, has very little inhibitory effect.

With oil-based paints, mildew progresses more readily on exterior flat house paint than on exterior semigloss or gloss enamel; paints or stains containing linseed oil are very susceptible to mildew. Of the available water-based paints, acrylic latex is the most resistant to mildew. Porous latex (water-based) paints without a mildewcide, applied over a primer coat with linseed oil, will develop severe mildew in warm, humid climates common in the South.

Mildewcides, poisons for mildew fungi, are often added to paints. The paint label should indicate if a mildewcide is present in the paint. If it is not, a mildewcide can sometimes be added by the local paint dealer. When properly applied to a clean surface, paint containing a mildewcide should prevent mildew for several years.

Prevention and Removal

For new wood surfaces in warm, humid climates, mildew can be prevented by using topcoats of paint containing zinc oxide and mildewcide over a primer coat that also contains a mildewcide. For mild cases of mildew, use a paint containing a mildewcide.

Mildew must be killed before wood is refinished, or the mildew will grow through the new paint coat or solid-color stain. To kill mildew, scrub the painted surface with a bristle brush or sponge and the following solution:

1/3 c household detergent

1 to 2 qt (5 percent) sodium hypochlorite
(household bleach)

2 to 3 qt warm water

This mixture can also be used to remove mildew from naturally finished or unfinished wood.

WARNING: Do not mix liquid household bleach with ammonia or with any detergents or cleansers containing ammoniacal Bleach and ammonia in combination are lethal, similar to mustard gas. People have died from breathing the fumes from such a mixture. Many household cleaners contain ammonia, so be extremely careful what type of cleaner is mixed with bleach.

If mildew has formed on an earlier coat of finish and subsequent coats have been applied without first cleaning the surface, the mildew can grow through the new coating. In this situation it is usually impossible to control the mildew. The entire paint coat should be stripped and a new finishing system applied.

Peeling and Cracking

Intercoat Peeling

Intercoat peeling is the separation of the new paint coat from the old, which indicates that the bond between the two coats is weak (Fig. 33). Intercoat peeling usually results from inadequate cleaning of the weathered surface prior to repainting. It generally occurs within 1 year of repainting. This type of paint peeling can be prevented by good cleaning and painting practices. Intercoat peeling can also occur on freshly painted wood if too much time elapses between application of the primer coat and topcoat. If more than 2 weeks elapse before a topcoat is applied to an oil-based primer, soap-like materials may form on the surface and interfere with the bonding of the topcoat. When the period between applications exceeds 2 weeks, the surface should be scrubbed before applying the second coat. If the primer coat is applied in the fall, do not wait until spring to apply the topcoat. If the lapse in time is unavoidable, the old primer paint should be washed and the surface reprimed before painting.

Cross-Grain Cracking

Cross-grain cracking occurs when paint coatings become too thick (Fig. 34). This problem often occurs on older homes that have been painted several times. Normally, paint cracks in the direction it was brushed onto the wood (that is, with the grain). Cross-grain cracks run across the grain of the wood and paint. Once cracking has occurred, the only solution is to completely remove the old paint and apply a new finishing system on the bare wood.

To prevent cross-grain cracking, follow the paint manufacturer's recommendations for spreading rates. Do not repaint unweathered, protected areas such as porch ceilings and roof overhangs as often as the rest

of the house. If possible, repaint these areas only as they weather and require new paint. If repainting is required, be sure to scrub the areas with a sponge or bristle brush and detergent in water to remove any water-soluble materials that will interfere with adhesion of the new paint. Latex paints, based on either vinyl or acrylic polymers, have not been known to fail by cross-grain cracking.

Blistering

Temperature blisters are bubble-like swellings that occur on the surface of the paint film as early as a few hours or as long as 1 to 2 days after painting. They occur only in the last coat of paint (Fig. 35). The blisters are formed when a thin, dry skin forms on the outer surface of the fresh paint and the liquid thinner in the wet paint under the skin changes to vapor and cannot escape. When the direct rays of the sun fall on freshly painted wood, the rapid rise in temperature causes the vapors to expand and produce blisters. Usually, only oil-based paint blisters are formed in this way. Dark colors that absorb heat and thick paint coats are more likely to blister than are white paints or thin coats.

To prevent temperature blisters, avoid painting surfaces that will soon be heated. The best procedure is to "Yellow the sun around the house." The north side of the building should be painted early in the morning, the east side late in the morning, the south side well into the afternoon, and the west side late in the afternoon. However, at least 2 hours should be allowed for the fresh paint film to dry before it cools to the point where condensation could occur. If blistering does occur, allow the paint to dry for a few days, scrape off the blisters, smooth the edges with sandpaper, and spot paint the area.

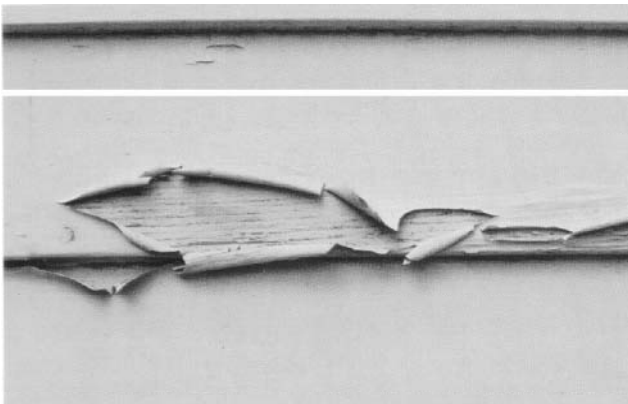

Figure 33---Intercoat peeling of paint is usually caused by poor preparation of the old surface.



Figure 34---Cross-grain cracking results from an excessive buildup of paint.



Figure 35---Temperature blisters can form when partially dried paint is suddenly heated by the direct rays of the sun. (M 147 706-5)

Moisture Blisters

Moisture blisters are also bubble-like swellings on the surface of the paint film. As the name implies, they usually contain moisture when they are formed. Moisture blisters may occur where outside moisture such as rain enters the wood through joints and other end-grain areas of boards and siding. Moisture may also enter because of poor construction and maintenance practices, particularly in the lower courses of siding. Paint failure is most severe on the sides of buildings that face the prevailing winds and rain. Damage appears after spring rains and throughout the summer. Moisture blisters may occur in both heated and unheated buildings.

Moisture blisters may also result from the movement of water vapor from within the house to the outside. Plumbing leaks and improper venting of bath and kitchen areas, clothes dryers, and humidifiers are sources of inside water. If the warm side of outside walls does not contain a vapor barrier, the moisture will move through the wall and result in moisture blisters or paint peeling. Such damage is not seasonal and occurs when the faulty condition develops.

Moisture blisters usually include all paint coats down to the wood surface. After the blisters appear, they dry out and collapse. Small blisters may disappear completely, but fairly large ones may leave a rough spot; in severe cases, the paint will peel (Fig. 36). Thin coatings of new, oil-based paint are the most likely to blister. Old, thick coats are usually too rigid to swell and form blisters, so cracking and peeling will result instead.

Elimination of moisture and use of a vapor barrier are the only practical ways to prevent moisture blisters in paint. The moisture source should be identified and

eliminated to avoid more serious problems such as wood decay (rot) and loss of insulating value.

Discoloration

In some species, such as western redcedar, cypress, and redwood, the heartwood is dark because of the presence of water-soluble extractives. The extractives give these species their attractive color, good stability, and natural decay resistance, but they can also discolor paint. The heartwood of Douglas-fir and southern yellow pine can also produce staining extractives, although the problem is not as severe as that encountered with western redcedar, cypress, and redwood.

When extractives discolor paint, moisture is usually the culprit. The extractives are dissolved and leached from the wood by water. The water then moves to the paint surface, evaporates, and leaves the extractives behind as a reddish-brown stain. The latex paints and the so-called breather or low-luster paints are more porous than conventional paints and thus more susceptible to extractive staining.



Figure 36---Paint can peel from wood when excessive moisture moves through the house wall. Some cross-grain cracking is also evident on this older house. (Photo courtesy of Southern Forest Products Association.)

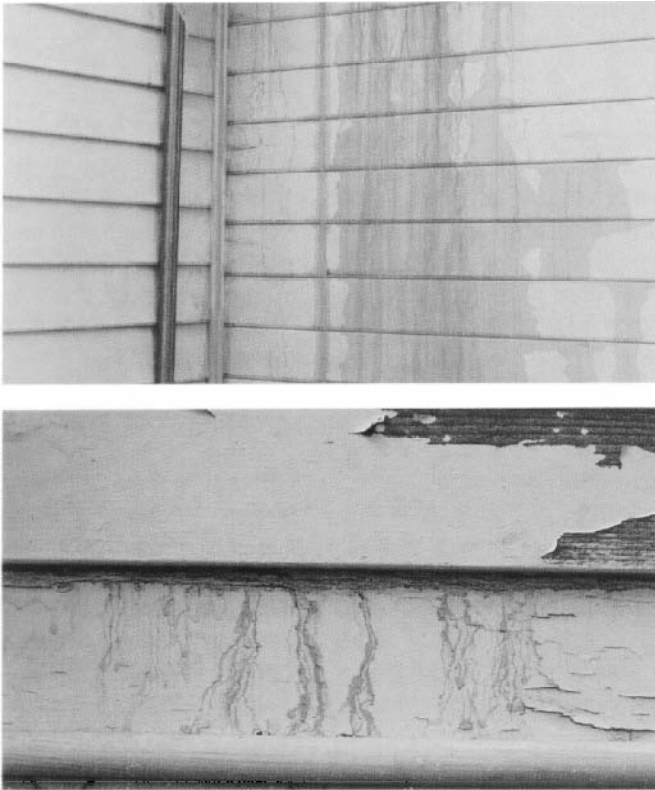

Figure 37---Streaked discoloration from water-soluble extractives. Discoloration can result from water wetting the back of one piece of siding and then running down the front of the next piece (top). Water that causes discoloration can also lead to paint failure (bottom). (MC83 9028, MC83 9027)

Diffused Discoloration

Diffused discoloration from wood extractives is caused by rain and dew that penetrate a porous or thin paint coat. It may also be caused by rain and dew that penetrate joints in the siding or by water from faulty roof drainage and gutters. Diffused discoloration is best prevented by following good painting practices.

Streaked Discoloration

streaked discoloration or rundown can also occur when water-soluble extractives are present in the wood (Fig. 37). This discoloration results when the back of the siding is wetted, the extractives are dissolved, and the colored water runs down the face of the adjacent painted boards from the lap joint. Streaked discoloration can also result from water vapor within the house moving to the exterior walls and condensing during cold weather. Major sources of water vapor are humidifiers, clothes dryers and showers that are not vented to the outside, normal respiration, and moisture from cooking and dishwashing. Streaked discoloration may also be caused by water draining into exterior walls from roof

leaks, faulty gutters, or rain blown through louvers in vents.

Streaked discoloration can be prevented by reducing condensation or the accumulation of moisture in the walls. A vapor barrier (such as a continuous 6-mil polyethylene sheet) should be installed on the inside of all exterior walls in new or remodeled houses located in climate zones where winter condensation can occur in walls. If a vapor barrier is not practical, the inside of all exterior walls should be finished with a vapor-resistant paint. Water vapor in the house can be reduced by venting exhaust fans in bathrooms and kitchens to the outside. Clothes dryers should also be vented to the outside and not to the crawlspace or attic. Humidifiers should be avoided, and if the house contains a crawlspace, the soil should be covered with a vapor barrier to prevent migration of water into the living quarters (see section on control of moisture content).

Rain water can be kept from entering the walls by proper maintenance of gutters and roof. For colder areas in the South, condensation in the attic can be prevented by installing adequate insulation and providing proper ventilation. For gable roofs, vents should be provided at the gable ends and should be about 1/300 of the ceiling area. More positive air movement can be obtained if additional openings are provided in the overhang. Hip roofs should have air-inlet openings in the louvers and several smaller roof vents near the edges.

To stop extractive discoloration, moisture problems must be eliminated. Streaked discoloration will usually weather away in a few months. However, discoloration in protected areas can become darker and more difficult to remove with time. In these cases, discolored areas should be washed with a mild detergent soon after the problem develops. Paint cleaners are also effective on darker stains. A solution containing 4 to 16 oz of oxalic acid per gallon of warm water may also be effective.

Wax Bleed

The petrolatum wax used as a water repellent in some hardboard siding products may cause a discoloration problem called wax bleed. This problem can often be corrected by washing the affected surface with a detergent and water. For more severe cases, the surface should be reprimed and topcoated after thorough washing and rinsing.

Chalking

Chalking results when a paint film gradually weathers or deteriorates, releasing individual particles of resin and

pigment. These particles act like a fine powder on the paint surface. Most paints chalk to some extent, which is desirable because chalking cleans the painted surface. However, chalking is objectionable when it washes down over a surface with a different color (Fig. 38) or when it causes premature disappearance of the paint film through excessive erosion. With colored or tinted paints, chalking is a common cause of fading.

Discoloration problems from chalking can be reduced by selecting paint with slow chalking tendencies. The manner in which a paint is formulated may determine how fast it chalking. Therefore, if chalking is likely to be a problem, select a paint that the manufacturer has indicated will chalk slowly.

For repainting surfaces that have chalking excessively, proper preparation of the old surface is essential if the new paint coat is expected to last. Scrub the old surface thoroughly with a detergent solution to remove all old deposits and dirt. Rinse thoroughly with clean water before repainting. The use of a top-quality oil-based primer or a stain-blocking acrylic latex primer may be necessary before latex topcoats are applied. Otherwise, the new paint coat will peel. Discoloration or chalk that has run down on a lower surface maybe removed by vigorous scrubbing with a good detergent. This discoloration will usually gradually weather away if the chalking problem on the painted surface has been corrected.

Exudation of Pitch

Pine and Douglas-fir can exude pitch (resin), and cedar species (except western redcedar) can exude oils. Pitch and oils are not ordinarily a problem because lumber manufacturers have learned how to “set” pitch and evaporate excess oil during the kiln-drying process. The material is simply planed or sanded later in the manufacturing process and does not present additional problems. However, where the proper schedules are not used in drying the lumber, problems can result,

When exudation occurs before the wood has been painted, the exuded materials should be removed. If the exuded pitch has hardened, it can be removed fairly easily with a putty knife, paint scraper, or sandpaper; however, if it is still soft, such procedures smear the pitch over the surface of the wood. If the pitch is not removed, the paint is likely to alligator, crack, and fail over the pitch-coated areas soon after painting. Soft pitch should be removed thoroughly by scrubbing the surface with cloths wet with denatured alcohol. After most of the pitch has been scrubbed off, the surface should be sanded. Any further exudation that occurs before subsequent coats of paint are applied



Figure 38—Chalking of paint. Some paints or stains chalk badly. Chalking can discolor a lower surface as the resin and pigment particles wash down.

should be removed by scrubbing the surface with alcohol.

If exudation occurs after the wood is painted, the wood might best be left alone until it is time to repaint. The wood should then be scraped thoroughly before new paint is applied. If a few boards in the structure are particularly unsightly because of exudation or because of early paint failure, it may be wise to replace them with new lumber before repainting.

Exudation of pitch is favored by fluctuations in temperature or by high temperatures. In extreme cases, boards have been known to continue to exude pitch for many years (Fig. 39). Repainting should be deferred until all exudation has ceased or until repainting has become necessary for other reasons. No paints and painting procedures can be relied upon to prevent exudation of pitch.

Stains

Stains can result from mechanical and natural causes. In this section, we will discuss iron stains, fungal blue stain, brown stain over knots, and water stain.

Iron Stains

Two types of stains are associated with iron. The red-brown discoloration caused by rust is associated with the use of ferrous nails and metal screens. Another stain, a blue-black discoloration, is caused by the

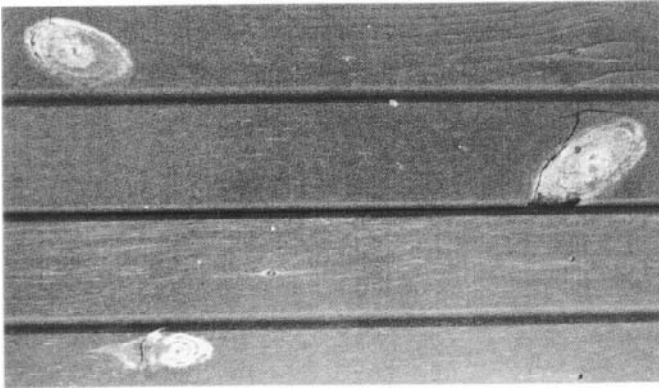

Figure 39---Exuded pitch from knots and pitch pocket on siding. (M84 0493-11)

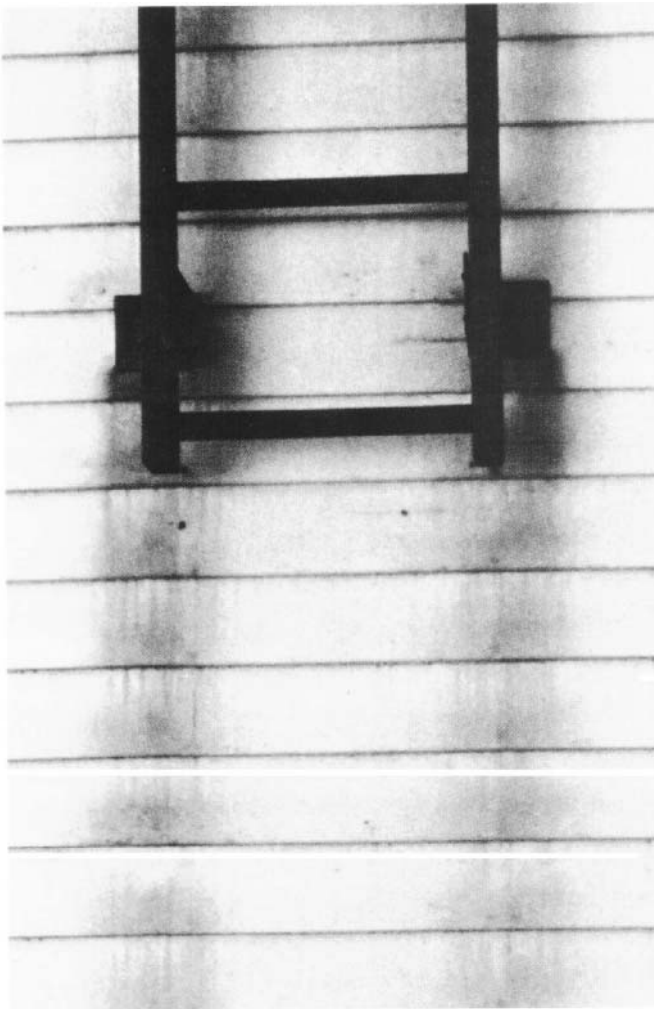

Figure 40---Metal fasteners or window screens can corrode and later discolor paint as leaching occurs. (M84 0490-4)

reaction of wood extractives with iron and is associated with the use of ferrous nails and with iron traces from tools.

Rust. When standard ferrous nails are used on exterior siding and the siding is painted, a red-brown

discoloration may appear through the paint in the immediate vicinity of the nailhead. To prevent rust stains, use corrosion-resistant nails. These include high-quality galvanized, stainless steel, and aluminum nails. The heads of poor-quality galvanized nails can be chipped when they are driven into the siding, corrode easily, and, like ferrous nails, cause unsightly staining of the paint. If rust is a serious problem on a painted surface, the nails should be countersunk and caulked, and the area should be spot primed and then topcoated.

Rust stains may also occur when standard ferrous nails are used in association with other finishing systems such as solid-color or opaque stains, semitransparent penetrating stains, and water-repellent preservatives. Rust stains can also result when screens and other metal objects that are subject to corrosion and leaching are fastened to the surface of the building (Fig. 40).

Chemical stains. An unsightly blue-black discoloration of wood can be caused by the chemical reaction of wood with iron. In this case, the iron reacts with certain wood extractives, such as tannins or tannic acid in cedar, redwood, or oak. Ferrous nails and other iron appendages are the most common source of iron in chemical staining (Fig. 41), but problems have also been associated with traces of iron left from cleaning the wood surface with steel wool, wire brushes, or even iron tools. The discoloration can sometimes become sealed beneath a new finishing system.

A solution of oxalic acid in water will remove blue-black discoloration providing it is not already sealed beneath a finishing system. The stained surface should be given several applications of a solution containing 1/2 to 1 lb of oxalic acid per gallon of hot water. After the stains disappear, the surface should be thoroughly washed with fresh warm water to remove the oxalic acid and any traces of the chemical causing the stain. If all sources of iron are not removed or protected from corrosion, staining re-occurs.

WARNING: Oxalic acid and its water solution are toxic and should be used with great caution.

Blue Stain

Blue stain is caused by microscopic fungi that commonly infect the sapwood of all woody species. Although microscopic, they produce a blue-black discoloration of the wood. Blue stain does not normally weaken wood structurally, but conditions that favor stain development are also ideal for serious wood decay and paint failure.

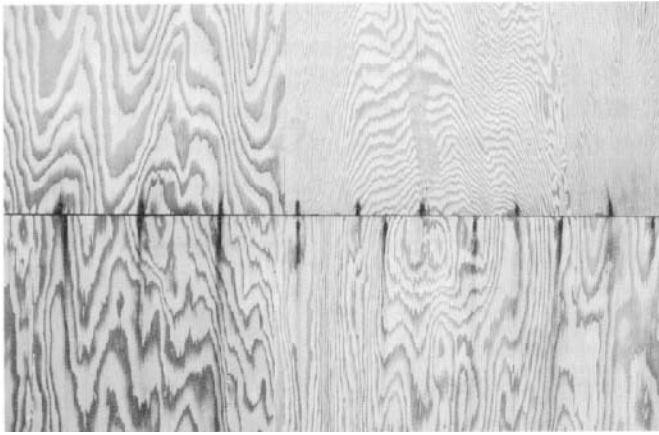

Figure 41—Blue-black discoloration resulting from the use of ferrous nails. (M84 0491)

Wood in service may contain blue stain, and no detrimental effects will result as long as the moisture content is kept below 20 percent. Wood in properly designed and well-maintained houses has a moisture content of less than 20 percent. However, if the wood is exposed to moisture from rain, condensation, or leaky plumbing, the moisture content will increase, the blue-stain fungi will develop further, and decay may even follow,

To prevent blue stain from discoloring paint, follow good construction and painting practices. First, do whatever is possible to keep the wood dry. Provide an adequate roof overhang, and properly maintain shingles, gutters, and downspouts. Window and door casings should slope out from the house, allowing water to drain away rapidly. In northern climates, use a vapor barrier on the interior side of all exterior walls to prevent condensation. Vent clothes dryers, showers, and cooking areas to the outside and avoid the use of humidifiers. Treat wood with a water-repellent preservative, then apply a nonporous mildew-resistant primer, and finally apply at least one topcoat of finish containing a mildewcide. If the wood has already been painted, remove the old paint and allow the wood to dry thoroughly. Apply a water-repellent preservative, and then repaint the wood.

A 5-percent solution of sodium hypochlorite (ordinary liquid household bleach) may sometimes remove blue-stain discoloration, but it is not a permanent cure. Be sure to use a fresh solution of bleach as its effectiveness can diminish with age. The moisture problem must be corrected to obtain a permanent cure for discoloration.

Brown Stain Over Knots

The knots in many softwood species, particularly pine, contain an abundance of resin. The resin can sometimes cause paint to peel or turn brown (Fig. 42). In

most cases, the resin is “set” or hardened by the high temperatures used in kiln drying of construction lumber.

Good painting practices should eliminate or control brown stain over knots. First apply a good primer to the bare wood and then apply two topcoats. For exterior wood, do not apply ordinary shellac or varnish to the knot area initially because this may result in early paint failure. Specialty primer paints are available to seal knots for outdoor painting. These primer paints work best under high-quality acrylic latex topcoat paints.

Water Stain

Wood siding can become water stained, particularly if it is left unfinished or if a natural finish has started to deteriorate (Fig. 5). Water stain is most common at the base of sidewalls where rainwater runs off a roof, hits a hard surface, and splashes back onto the side of the building. The water causes the finish to deteriorate quickly in this area. If the finish is not replaced, the water can begin to remove the water-soluble extractives, which accelerates the weathering process, and the area becomes stained. Water stain can also be seen where gutters overflow. Good construction practices that keep water from contacting the wood should be followed whenever possible to prevent water stain. The wood should be treated regularly with a water-repellent preservative. Removing water stains can be very difficult. Sometimes scrubbing with mild detergent and water is effective. Light sanding may be effective on smooth wood surfaces. Bleaches such as liquid household bleach or oxalic acid solutions have been used with varying degrees of success.



Figure 42—Brown discoloration of paint caused by resin exudation from a knot. (M84 0492-4)

Sources of Information on Exterior Wood Finishings

Cassens, D.L.; Feist, W.C. 1983. Finishing hardwood floors and millwork. In: Carter, R.M., ed. *Finishing Eastern Hardwoods*. Madison, WI: Forest Products Research Society: 86-95.

Cassens, D.L.; Feist, W.C. 1986. Finishing wood exteriors. Selection, application, and maintenance. *Agric. Handb. No. 647*. Washington, DC: U.S. Department of Agriculture. 56 p.

Cassens, D.L.; Feist, W.C. 1988. Wood finishing: Discoloration of house paint—causes and cures. *North Central Reg. Ext. Pub.* 134.

Cassens, D.L.; Feist, W.C. 1988. Wood finishing: Finishing and maintaining wood floors. *North Central Reg. Ext. Pub.* 136.

Cassens, D.L.; Feist, W.C. 1988. Wood finishing: Finishing exterior plywood, hardboard, and particle-board. *North Central Reg. Ext. Pub.* 132.

Cassens, D.L.; Feist, W.C. 1988. Wood finishing: Paint failure problems and their cure. *North Central Reg. Ext. Pub.* 133.

Cassens, D.L.; Feist, W.C. 1988. Wood finishing: Selection and application of exterior finishes for wood. *North Central Reg. Ext. Pub.* 135.

Feist, W.C. 1983. Finishing wood for exterior use. In: Carter, R.M., ed. *Finishing Eastern hardwoods*. Madison, WI: Forest Products Research Society: 185-198.

Feist, W.C. 1984. Painting and finishing wood for use outdoors. In: *Proceedings, 7th annual educational conf.*; Baltimore, MD: American Society of Home Inspectors: 1-27.

Feist, W.C. 1986. Protective finishes and coatings for wood. In: Bever, M.B., ed. *The encyclopedia of materials science and engineering*. Oxford, England: Pergamon Press: 3981-3982.

Feist, W.C. 1987. Weathering performance of finished yellow-poplar siding. *Forest Products Journal.* 37(3): 15-22.

Feist, W.C. 1988. Weathering of wood and its control by water-repellent preservatives. In: *Proceedings 47358, Wood protection techniques and the use of treated wood in construction*; 1987 October 28-30; Memphis, TN. Madison, WI: Forest Products Research Society: 82-88.

Feist, W.C. 1988. Weathering performance of finished southern pine plywood siding. *Forest Products Journal.* 38(3): 22-28.

Feist, W.C. 1989. Protective finishes and coatings for wood. In: Schniewind, A.P., ed. *Concise encyclopedia of wood and wood-based materials*. Oxford, England: Pergamon Press: 230-232.

Feist, W.C. 1990. Outdoor wood weathering and protection. In: Rowell, R., ed. *Archaeological wood, properties, chemistry, and preservation. Advances in Chemistry Series 225*. Washington, DC: American Chemical Society. Chapter 11.

Feist, W.C.; Little, J.K.; Wennesheimer, J.M. 1985. The moisture-excluding effectiveness of finishes on wood surfaces. *Res. Pap.* 462. Madison, WI: U.S. Department of Agriculture, Forest Service, Forest Products Laboratory. 38 p.

Feist, W.C.; Oviatt, A.E. 1984. Wood siding—installing, finishing, maintaining. *Home and Garden Bull.* 203. Madison, WI: U.S. Department of Agriculture, Forest Service, Forest Products Laboratory. 24 p.

Feist, W.C.; Peterson, G. 1987. Protecting wood from humidity. *Fine Woodworking.* 64: 59-61.

Forest Products Laboratory. 1987. *Wood handbook: Wood as an engineering material. Agric. Handb. 72. (Rev.)*. Washington, DC: U.S. Department of Agriculture. Chapter 16. Finishing of wood.

Gorman, T.M.; Feist, W.C. 1989. Chronicle of 65 years of wood finishing research at the Forest Products Laboratory. *Gen. Tech. Rep. FPL-GTR-60*. Madison, WI: U.S. Department of Agriculture, Forest Service, Forest Products Laboratory. 81 p.

Ingram, L.L., Jr.; McGinnis, G.D.; Pope, P.M.; Feist, W.C. 1983. Effect of coating systems on the vaporization of pentachlorophenol from treated wood. *Proceedings, 79th annual meeting, American Wood Preserver's Association*; 79: 32-41.

⁵ Available from the Forest Products Laboratory, One Gifford Pinchot Drive, Madison, WI 53705-2398 or from the U.S. Government Printing Office, North Capitol and H Streets NW, Washington, DC 20402.



Caution

The pesticides—wood preservatives, mildewcides, and fungicides—described in this report were registered for the uses described at the time the report was prepared. Registrations of pesticides are under constant review by the Environmental Protection Agency. Therefore, consult a responsible State agency on the current status of any pesticide. Use only pesticides that bear a Federal registration number and carry directions for home and garden use.

Pesticides used improperly can be injurious to humans, animals, and plants. Follow the directions and heed all precautions on the label. Avoid inhalation of vapors and sprays; wear protective clothing and equipment if these precautions are specified on the label.

If your hands become contaminated with a pesticide, do not eat, drink, or smoke until you have washed. If you swallow a pesticide or if it gets in your eyes, follow the first aid treatment given on the label and get prompt medical attention. If a pesticide gets onto your skin or clothing, remove the clothing immediately and wash skin thoroughly.

Store pesticides and finishes containing pesticides in their original containers out of the reach of children and pets, under lock and key. Follow recommended practices for the disposal of surplus finishing materials and containers. Scraps of chemically treated wood or finished wood should never be burned, either for heat or for disposal. Toxic fumes may be released. Dispose of the material through ordinary trash collection or burial.

Appendix A

Conversion Table for SI Units

Type of measurement	Unit of measurement
Area	1 ft ² = 0.093 m ²
Length	1 ft = 0.3 m 1 in. = 25.4 mm 1 mil = 0.025 mm
Mass	1 lb = 0.45 kg
Temperature	°C = (°F - 32)/1.8
Volume	1 c = 0.236 liter 1 fluid oz (U.S.) = 29.57 ml 1 gal (U.S.) = 3.785 liters 1 pint (U.S.) = 0.473 liter 1 quart (U.S.) = 0.9463 liter

Appendix B

Consumer Information⁶ Inorganic Arsenical Pressure-Treated Wood (including: CCA, ACA, and ACZA)

Consumer Information

This wood has been preserved by pressure-treatment with an EPA-registered pesticide containing inorganic arsenic to protect it from insect attack and decay. Wood treated with inorganic arsenic should be used only where such protection is important.

Inorganic arsenic penetrates deeply into and remains in the pressure-treated wood for a long time. Exposure to inorganic arsenic may present certain hazards. Therefore, the following precautions should be taken both when handling the treated wood and in determining where to use or dispose of the treated wood.

Use Site Precautions

Wood pressure-treated with waterborne arsenical preservatives may be used inside residences as long as all sawdust and construction debris are cleaned up and disposed of after construction.

Do not use treated wood under circumstances where the preservative may become a component of food or animal feed. Examples of such sites would be structures or containers for storing silage or food.

Do not use treated wood for cutting-boards or countertops.

Only treated wood that is visibly clean and free of surface residue should be used for patios, decks, and walkways.

Do not use treated wood for construction of those portions of beehives which may come into contact with the honey.

Treated wood should not be used where it may come into direct or indirect contact with public drinking water, except for uses involving incidental contact such as docks and bridges.

Handling Precautions

Dispose of treated wood by ordinary trash collection or burial. Treated wood should not be burned in open fires or in stoves, fireplaces, or residential boilers because toxic chemicals may be produced as part of the smoke and ashes. Treated wood from commercial or industrial use (e.g., construction sites) may be burned only in commercial or industrial incinerators or boilers in accordance with state and Federal regulations.

Avoid frequent or prolonged inhalation of sawdust from treated wood. When sawing and machining treated wood, wear a dust mask. Whenever possible, these operations should be performed outdoors to avoid indoor accumulations of airborne sawdust from treated wood.

When power-sawing and machining, wear goggles to protect eyes from flying particles.

After working with treated wood, and before eating, drinking, and using tobacco products, wash exposed areas of skin thoroughly.

If preservatives or sawdust accumulate on clothes, launder before reuse. Wash work clothes separately from other household clothing.

⁶ *consumer information sheet* approved by the U.S. Environmental Protection Agency, January 1986.